

# SIKA Level Switch

**SIKA**<sup>®</sup>  
founded 1901  
Dr. Siebert & Kühn GmbH & Co. KG



# SIKA Level Switch

## Safety at a high level!



### Convincing Advantages

- easy and reliable method to monitor fluid levels
- proven float principle
- easy side installation using threads 3/4" or 1/2" BSP
- potential-free contact as signalling transmitter

### SIKA-level controller in service as

- run dry protection for pumps (minimum alert)
- spill protection (maximum alert)
- leakage monitoring
- screwed-connection oil level monitoring gauge, e.g. at compressors

### Function mode

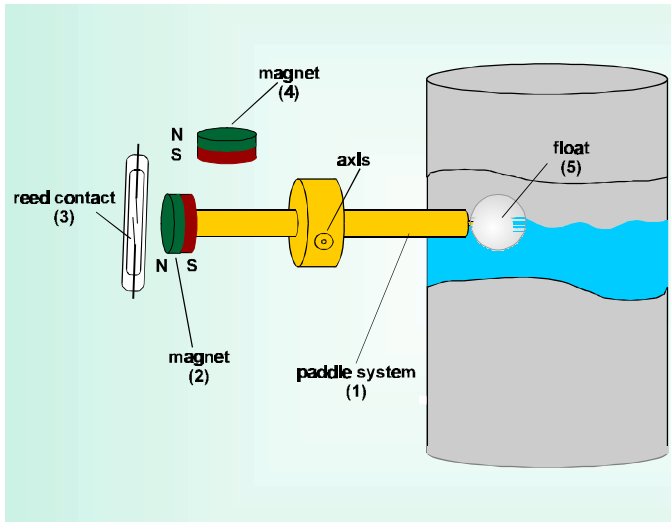

The rising level in the tank forces the float (5) up. Via paddle system (1), the magnet (2) changes its position relative to Reed contact (3) and actuates it. The repulsion between the two homopolar magnets (2) and (4) supports the buoyancy (Version VK... different). As soon as the level sinks again, the float (5) follows also and actuates the Reed contact again.

Works adjusted switching function

- contact makes with rising level
- contact opens with falling level can be changed by the customer.

The Reed contact (3) used as signalling transmitter consists of two ferromagnetic contact making tongues positioned in a shielding gas filled glass bulb. As a result, burned contacts are virtually eliminated. This construction enables a durability up to 100.000.000 switching cycles.

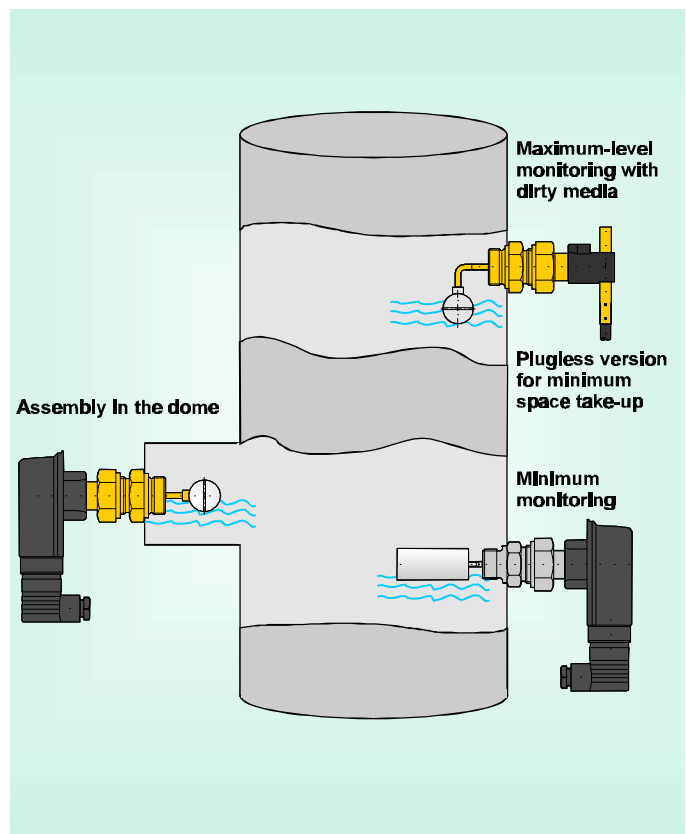

## Versions / Order No

Order example	VH	S	0	0	M	MS
Metal version	VH					
Plastic version	VK					
Plug connection, standard: EN 175301-803-A (options: see below)		S				
1,5 m connecting cable		6				
			0			
• 3/4" BSP male, ball float PVDF				0		
• 3/4" BSP male, stainless steel float (only available for VH... types)				2		
• 3/4" BSP male, elbow float bar, ball float PVDF (only brass and stainless steel version)				3		
• 1/2" BSP male, float PVDF				4		
					M	
Brass version						MS
Stainless steel version						VA
Plastic version						—

## Options

Please, indicate options in the case of orders in plain text!

- Plug connector EN 175301-803-A inclusive cable box with optical level indication by two LED's in the plug (for rated voltages 24 V...230 V AC/DC)
- 4-pin sensor plug M12x1  
Connecting cables with extension sockets available as accessory  
length:     3 m           Order no:     XVT 2053  
              5 m           XVT 2009  
              10 m          XVT 2070
- Reed contact with high contact rating, 60 VA
- integrated Triac switching amplifier
- OEM versions, proven in numerous serial uses, on request

## Stock types

Standard devices for water and oil applications, available ex stock

- VHS 00 M - MS (see photograph below)
- VH 600 M - MS (see photograph page 2)

**Build up your individual level switch yourself!**

**Electrical connection**

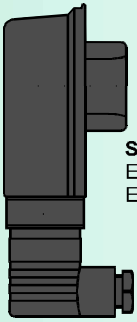

**Standard plug::**  
Elbow plug connector  
EN 175301-803-A

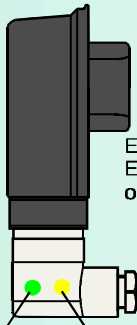

Elbow plug connector  
EN 175301-803-A with  
optical level indication



power level

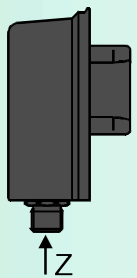

4-pin sensor  
plug M12x1

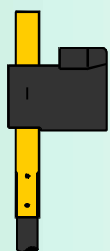
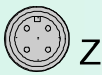

without plug,  
1,5 m cable

**Material**

brass

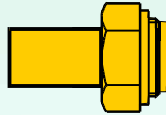

stainless steel

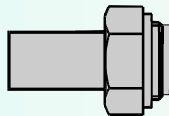

plastic



**Connection thread**

3/4" BSP male



1/2" BSP male

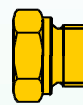

**Float**

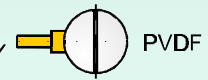

stainless steel



only brass or  
stainless steel version

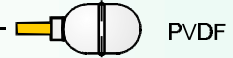
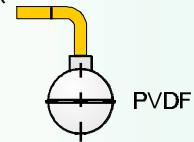

Example:  
VHS 00 M-MS

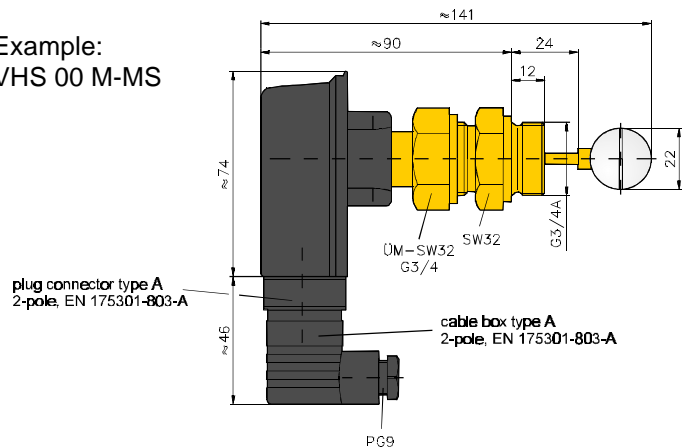

## Technical Data

Minimum medium density	PVDF-float	0,78 kg/dm <sup>3</sup>
	stainless steel cylinder float	0,83 kg/dm <sup>3</sup>
Maximum medium temperature	Metal version VH ...	110 °C
	Plastic version VK ...	100 °C
Maximum ambient temperature	VHS .../ VKS ...	80 °C
	VH 6 ...	110 °C
	VK 6 ...	80 °C
Nominal pressure	Metal version VH ...	PN 25
	Plastic version VK ...	PN 10
Materials (important)	Brass version	CW614N (2.0401)
	Stainless steel version	1.4571
	Plastic version	PPO Noryl GFN3 Connection thread 1.4571
Activation point, related to middle axis (water, 20 °C), elbow version different		- 4 ... 0 mm
Switching hysteresis, elbow version different		approx. 1 ... 4 mm
Switching function		“Contact opens” with falling level (changeable to “make-contact”)
Max contact rating		max. 1 A max. 230 VAC or 48 VDC max. 26 VA or 20 W
Type of protection		IP 65
Electrical connection		Plug connector EN 175301-803-A including cable box, suitable for cables of outside diameter 4,5. to 7 mm, others see options (page 3)