

LN1000 Intrinsically Safe Annunciator

Modular alarm system for all hazardous areas

ATEX Certified Ex II 1G,
EEx ia IIC T4

Ideal for installation in any zone

Up to 32 channels can be
powered through one
IS interface

Field-mounting product:
flameproof or purged cabinets
not required

User-programmable alarm
sequences to ISA-S18.1 1979

Compatible with a range of
intrinsically safe audible and
visual alarms

Alarm indication by combined
bright LEDs and LCDs

The LN1000 Intrinsically Safe Annunciator provides a unique solution for problems with hazardous area alarm indication. The Annunciator provides a visual display of the alarm status including 'first-up' information and can be mounted in the hazardous area for the benefit of operators working in any zone.

The lightweight stainless steel construction gives a compact and simple to install modular unit which can easily be expanded by the addition of extra Alarm Cards.

Maintenance can be carried out live without the necessity of 'gas checks' or prior shutdown. Unlike explosionproof, purged and type 'n' systems, installation is simple and relatively low cost.

With the addition of a number of ancillary devices a complete intrinsically safe alarm and control package can be provided.



Features & Benefits

Lightweight

The LN1000, being constructed from stainless steel and polyurethane mouldings, is extremely lightweight in comparison to conventional explosionproof and purged systems. This gives great benefits where space and payload are critical factors, especially offshore.

Fully Field Programmable

Each two way alarm card is programmable for different alarm sequences and different functionality.

Time Delays

Each alarm input has a DIL switch selectable adjustable time delay of between 3 and 30 seconds to eliminate false alarms caused, for example, by surging liquids.

System Size

Two chassis sizes are available: 12way and 32way, with the number of two Channel Alarm Cards added to suit the application. Further Alarm Cards can be slotted in at a later date if necessary. Larger systems can be created by linking chassis together.

Extremely Lower Power

Even the 32 channel Annunciator complete with repeat relays on all channels can be powered from a single isolating interface. The WIS1212 is recommended.

First-Up

In alarm annunciation applications it is often essential to know which alarm occurred first in a particular group. To this end, three different first-up sequences and seven different first-up groups are available, all programmable by DIL switches.

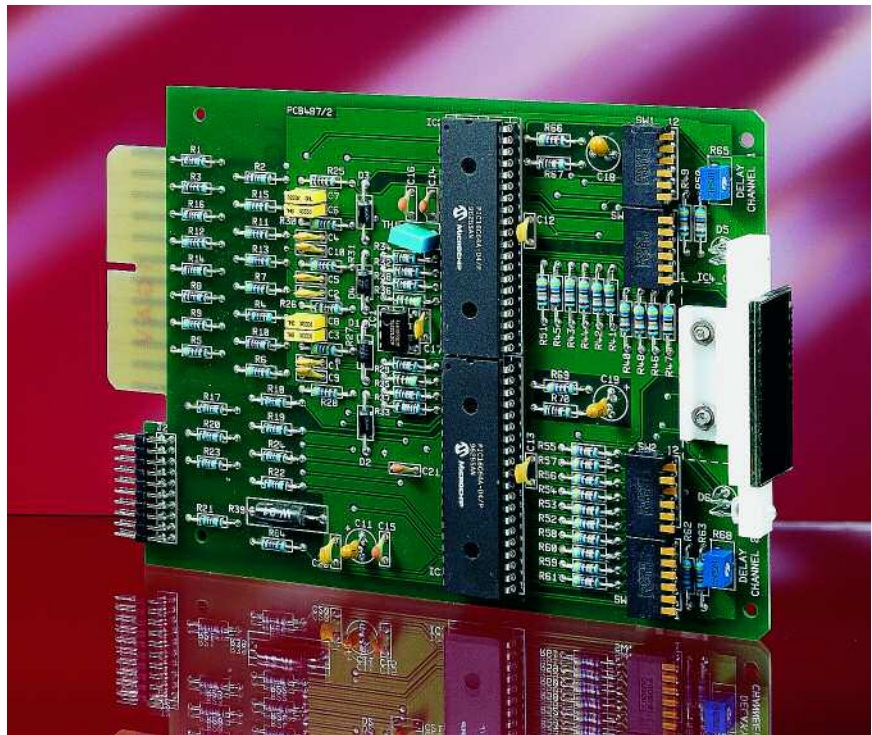
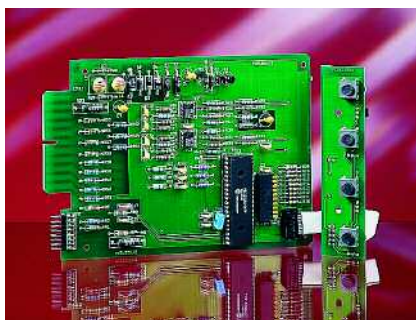

Servicing

Because the unit is intrinsically safe, live inspection and maintenance procedures can be carried out at any time. All configuration and maintenance is carried out from the front by simply removing the front facia and withdrawing the cards.

Installation

Installation is relatively simple using intrinsically safe equipment. There is no complicated purged panels to control and no need for explosionproof conduit etc. The front of the unit is sealed to IP65 so is suitable for mounting out in the field in harsh environments.

Mounting

The standard certified product is normally supplied for panel mounting into the customer's control system. As an extra service RTK can supply the Annunciator pre-mounted into an IP65 stainless steel wall mounting cabinet. For ease of site wiring the LN1000 is then supplied pre-wired to a row of terminals ready for external connection via the bottom gland plate. Two types of wall mounting wiring are available, one with all connections taken to terminals and a lower cost version which just has the basic alarm contact and common outputs wired to terminals.

Group Outputs

The Sequence Card has outputs to drive external sounders and also two group outputs which are DIL switch selectable to follow the alarm logic or the alarm contacts. In conjunction with these group outputs each alarm channel also has two outputs configurable to follow the alarm contact, the audible or the alarm logic. These outputs can be linked to provide group relay outputs for different alarm priorities and give a control output to third party equipment in the safe or hazardous area.

Complete Alarm Package

As specialists in the supply of all types of alarm products RTK can provide all the components necessary to produce a complete alarm package or can even provide the whole package fully wired and ready to install.

Typical Applications

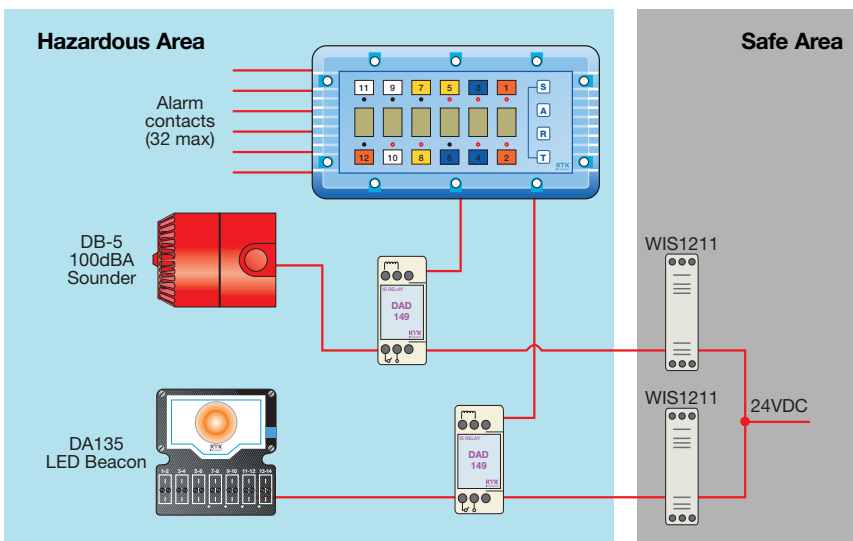
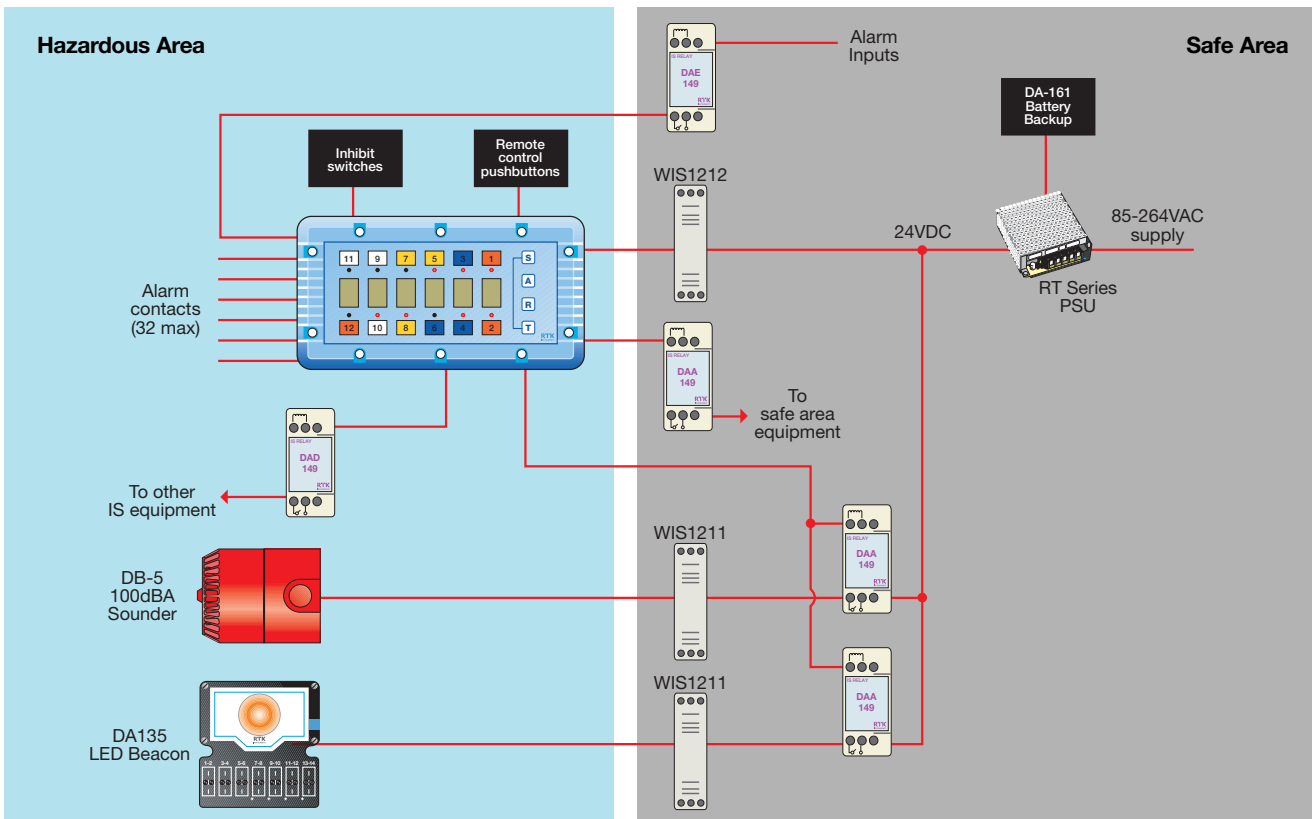

► By controlling the supply from an WIS1211 with a DAD149 IS Relay in the hazardous area (left). This alternative arrangement can provide considerable savings in cable costs in some applications.

IS Interface

The Annunciator and the optional warning devices each operate from any suitable 24VDC supply through an IS isolating interface unit. The recommended interfaces are the RTK WIS1200 Series which, owing to their input/output isolation, do not need a high integrity earth and are therefore easy to install.

IS Relays

The DA-149 Series of IS Relays are used for transferring status signals to and from hazardous and safe areas. These unique solid state devices act like the coil and contacts of an electromechanical relay.

Power Supply Units

The RT Series Power Supplies will conveniently provide a 24VDC supply from the AC mains to power circuits protected by the WIS1200 Series units. A separate battery backup unit, the DA-161, is available for use with the RT PSU.

The LN1000 Intrinsically Safe Alarm Annunciator functions in the same manner and with the same operational logic as conventional flashing-light alarm panels.

The system is extremely flexible. In its simplest form it consists of a 24VDC power supply, an isolating interface, and a 12 or 32 channel annunciator – shown in the diagram above.

For both large and small systems, the DA-149 Intrinsically Safe Relays are ideal for transferring signals from safe to hazardous areas or in the opposite direction or even within a hazardous area.

Additional audible and visual warning devices can be connected to provide the clearest possible method of attracting the operator's attention.

IS Warning Devices

For large and small systems, the 100dBA DB-5 Sounder and/or a DA135 LED Beacon can be added to attract the operator's attention in noisy environments. Each can be driven in either of two ways:

- By controlling the 24VDC supply with a DAA149 IS Relay in the safe area (top).

System Operation

Displays

The Annunciator functions in a similar manner to a conventional, safe area annunciator, but because of the limited power available the standard backlit display window is changed to a combined high brightness LED and an LCD.

When an alarm occurs a sounder and/or a beacon will be activated to attract the operator's attention. A high brightness LED on the LN1000 facia will pinpoint the affected channel(s). A customised legend gives details of the plant parameter that needs attention.

The LCD display gives further details of the alarm situation such as which alarm occurred first and whether the alarm condition has returned to normal.

The LED will always follow the ISA alarm sequence selected. The LCD display can take any of the seven forms shown, where 'F' indicates the first alarm to occur in that first-up group and 'I' shows that channel is currently inhibited. 'N' always indicates that the alarm contacts are in the normal (non-alarm) state.

Process Abnormal		Process Normal
A	Alarm	A_N
A^F	First Alarm	A^F_N
I	Point Inhibited	I_N
	Annunciator Reset	N

Controls

The operator will respond to an alarm situation by pressing the appropriate pushbuttons as follows:

Silence

S Silences both the local horn and any sounder connected to the EXT SOUND output. Has no effect on the visual display. This is always overridden by a new alarm.

Acknowledge

A Indicates recognition of a new alarm. The exact operation of the unit will depend on the alarm sequence selected.

Reset

R Returns the system to normal so the next alarm that occurs will be a first-up.

Test

T The test pushbutton simply illuminates all LED and all LCD segments to ensure all displays are functioning correctly.

System Test

S T By pressing Silence and Test simultaneously the System Test function is initiated. This will simulate an alarm on all inputs to test the full operation of the complete system.

Terminals are also available for additional external pushbuttons to be connected to the Annunciator.

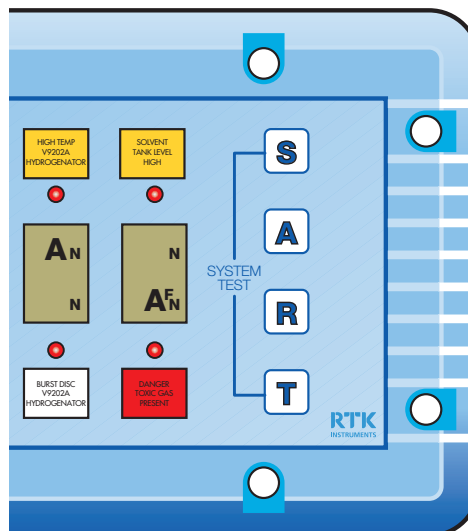

Programming

Each channel of the annunciator can be programmed independently to respond in a pre-determined manner to the inputs from the alarm contacts on the plant and the operator's pushbuttons. A range of ISA alarm sequences are supported and selected by DIL switches. The following are details of the main programmable features:

- ▶ Alarm contacts may be normally open or normally closed.
- ▶ After an alarm has been acknowledged the LN1000 may return to normal automatically as soon as the contact does so, or it may require to be reset manually.
- ▶ A 3-30 second time delay may be added to eliminate false triggering of alarms.
- ▶ Each alarm can be selected into one of seven first-up groups or no group.
- ▶ The unit can be programmed for three different first-up sequences or ringback sequence. Ringback indicates to the operator when an alarm contact has returned to the normal (non-alarm) state.
- ▶ The audible can be set to resound after a programmable time delay.
- ▶ Group Outputs and Alarm Outputs can be configured to follow the alarm logic, follow the audible or follow the alarm contacts. All these outputs can be set to drive high or low.

Ancillary Equipment

As a leading supplier of Alarm Annunciators and Alarm Systems, RTK Instruments is able to specify, design, manufacture and commission a complete alarm system for the client's exact application and industry requirements.

The parts shown below detail some key components that are used in these hazardous area alarm systems but many other options are available from the range of safe and hazardous area Alarm and Display Products.



WIS Series Intrinsically Safe Isolators



The WIS1200 Series of Alarm/Solenoid Drivers are suitable to drive the Annunciators, Sounder, Beacons and other display devices and as they are all manufactured by RTK Instruments have the benefit of been proven together as a system with the appropriate field mounted device.

Field or Panel Mount Intrinsically Safe Displays



These displays can be directly connected to the field mounted transmitter or sensor and can be used to display the desired parameter but also provide an alarm input into the LN1000 to make up a complete display and alarm package.

DA-149 Intrinsically Safe Relays



An essential interface between safe and hazardous area equipment and different units within the hazardous area, this unique design simulates an electromechanical relay but uses only a fraction of the normal current required. The inputs and outputs are certified as equivalent to "simple apparatus" so simplifying overall system design.

DA135 Intrinsically Safe Beacons



Driven from the group outputs of the LN1000 these high brightness warning Beacons will attract an operator's attention even in areas of extremely high ambient noise levels. IP65 and fully encapsulated, this rugged design is suitable for all harsh environmental conditions.

DB5 and DB7 Intrinsically Safe Sounders



Triggered from the LN1000 these IP65 certified Sounders have outputs greater than 100dBA. The user can select from 26 different tones.

RT Series PSU



A range of industrial Power Supplies to convert from various AC or DC supply voltages.

DA-161 Battery Backup

Can be used in conjunction with the RT Series Power Supplies.

Sequence Tables

Each alarm channel can be configured to suit the operating sequence required as listed in the ISA publication *Annunciator*

Sequences and Specifications S18.1 1979 (R1985). Systems can be configured with different features on different alarm ways

and there is no need to switch the power off. The diagram below shows the most commonly used sequences.

MANUAL RESET Sequence Code M

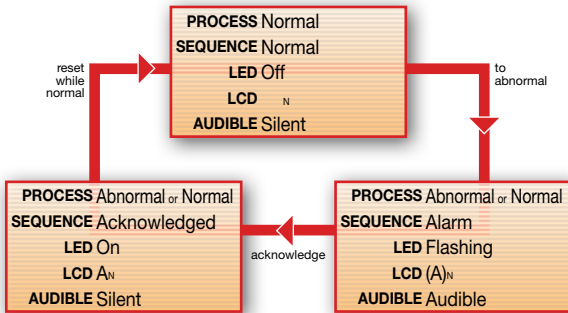

AUTOMATIC RESET Sequence Code A

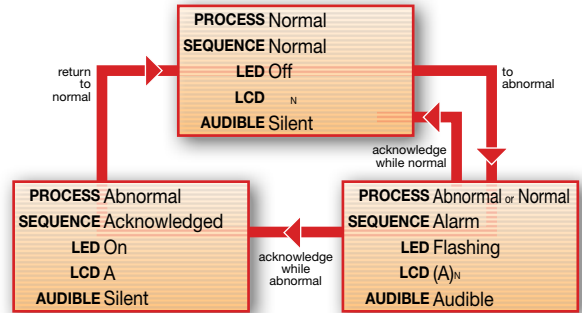

MANUAL RESET FIRST OUT WITH NO SUBSEQUENT ALARM FLASHING AND SILENCE PUSHBUTTON Sequence F2M-1

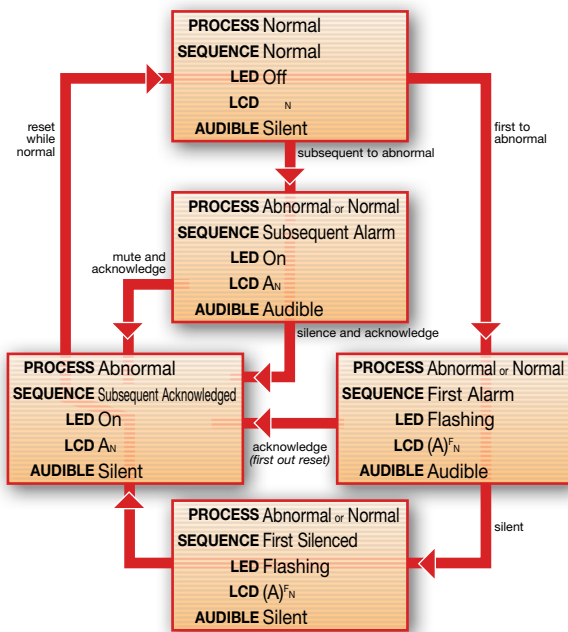

AUTOMATIC RESET FIRST OUT WITH FIRST OUT FLASHING AND RESET PUSHBUTTON Sequence F3A

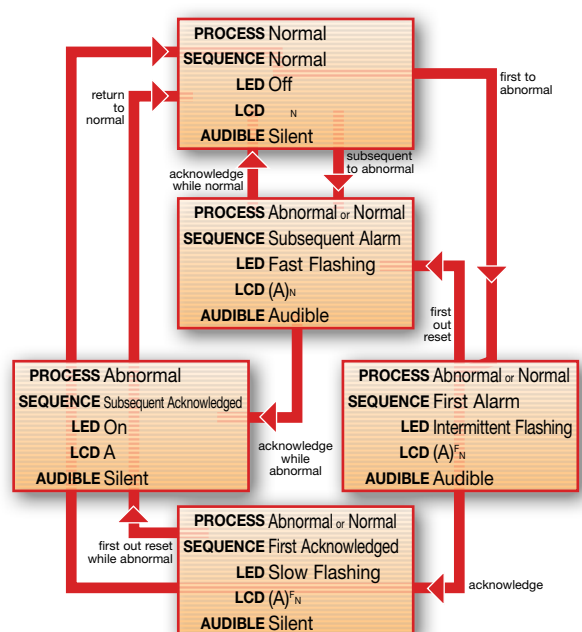

AUTOMATIC RESET FIRST OUT WITH NO SUBSEQUENT ALARM STATE Sequence F1A

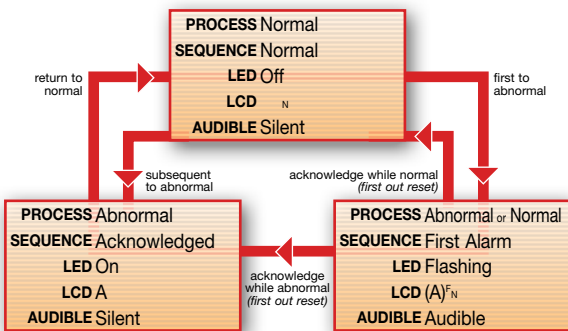

RINGBACK Sequence Code R

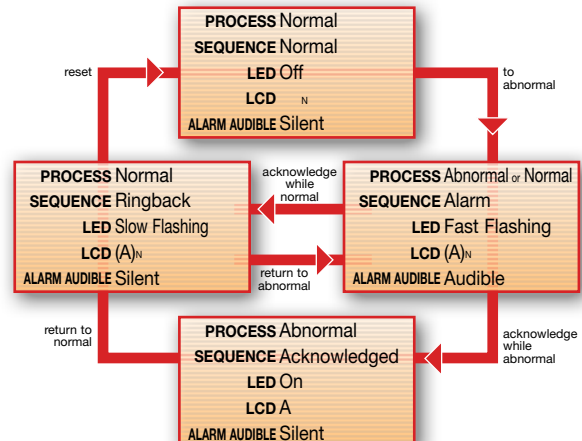

- (A) = A flashing
- N = On when contacts in normal state
- F = First-up alarm

Installation and Mechanical Details

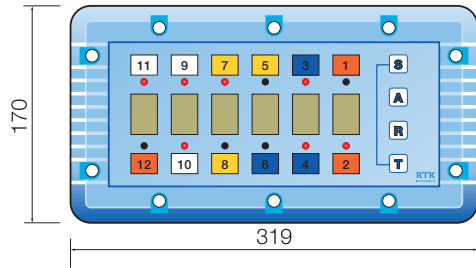

12-way panel mount

Panel Cutout
121 x 270±0.5mm

Recommended
Panel Thickness
Steel: 1.6–4.0mm
Aluminium: 2.0–4.0mm

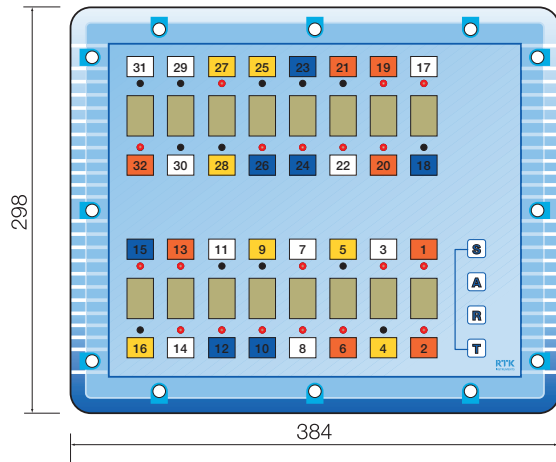
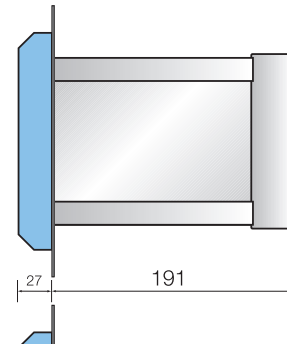

32-way panel mount

Panel Cutout
249 x 335±0.5mm

Recommended
Panel Thickness
Steel: 1.6–4.0mm
Aluminium: 2.0–4.0mm

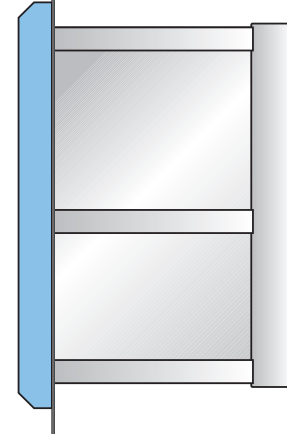

12-way wall mount

Depth 240mm

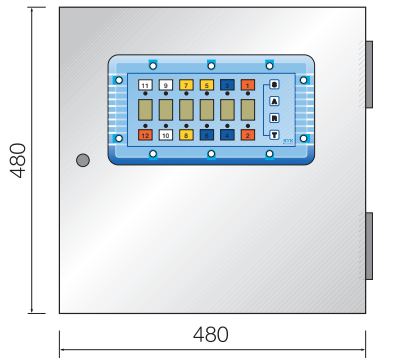

Cable entry at bottom

32-way wall mount

Depth 240mm

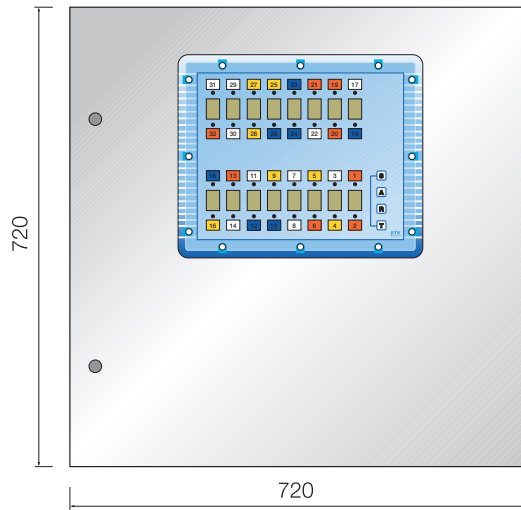

Engraving

The legends identifying each channel are engraved on 1.6mm Traffolyte to customers' requirements. They are located behind the front panel membrane and can be changed on site if necessary. The standard colour is black text on a white background but can optionally be in the following colour combinations:

Black text on orange or yellow backgrounds

White text on black, red, green, blue or brown backgrounds.

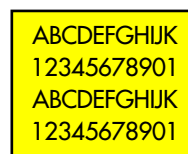

2.8mm characters



4mm characters



6mm characters

Technical Specification

Safety Description

Certification

ATEX certified to EN50014:1997, EN50020:2002 and EN50284:1999
Group II, Category 1G, EEx ia IIC T4
(Ta -20°C to +60°C)

Location

Equipment and related alarm contacts can be located in Zones 0, 1 or 2, Gas Group IIC, IIB or IIA, Temp Class up to T4

Certificate No.

Baseefa02ATEX0184

Safety Parameters

Ui = 30V
Ii = 165mW
Pi = 1.2W
Ci = 47nF
Li = 0.44mH

The device can be powered from an EEx ia IIC certified interface with output parameters lower than those shown above. Please see the EC Type Certificate for all the safety parameters of the inputs and outputs.

Recommended Interfaces

IS Isolators: WIS1212

Inputs

Alarm Inputs

User selectable as normally open or normally closed.
LN1000-12: maximum 12 inputs which must be isolated
LN1000-32: maximum 32 inputs which must be isolated

Inhibit Inputs

Each alarm channel can be individually inhibited to prevent alarms being activated.

Pushbutton Inputs

As standard four membrane pushbuttons are fitted to the front facia, however, terminals are provided so remote pushbuttons can be wired into the LN1000. Pushbuttons are: Test, Acknowledge, Reset, Silence.

Outputs

Sequence Card Outputs

Ext Sound: Used to switch a DA-149 IS Relay to control external sounders

Groups: Two group outputs to drive DA-149 IS Relays. One is configurable to follow the alarm logic or alarm contacts and the second works as a reflash output which gives a 1 second pulse on the occurrence of each new alarm.

Alarm Card Outputs

Each 2 channel alarm card has two group outputs per alarm channel. These can be configured to follow the alarm logic, follow the input or follow the horn.

These outputs are ideal to drive the DA-149 IS Relays which in turn can be used to control external safe or hazardous area mounting equipment.

General

Supply

Via suitably certified isolated interface sited in the safe area; the WIS1212 is recommended.

Power requirements

18-35VDC at 75mA max into the WIS1212 interface.

EMC Compliance

Immunity to EN61000-6-2:2001
Emissions to EN61000-6-4:2001

Environment

Operating temperature: 0 to 60°C
Storage temperature: -20 to 80°C
Humidity: 0-95% RH, non condensing

Protection (Panel Mount)

Door to case and case to panel: IP65
Rear of enclosure: IP20

Protection (Wall Mount)

IP65

Connection

Rising clamp type terminals, for conductors up to 2.5mm²

Recommended cable

0.5 to 2.5mm² two core with earthed screen and insulated sheath

Construction

Case: Stainless steel
Front facia: High impact resistant polyurethane
Membrane: Polyester

Weight

12 way panel mount: 3.8kg
32 way panel mount: 8.0kg
12 way wall mount: 20.0kg
32 way wall mount: 44.0kg
Above is for the chassis c/w Sequence Card – add 120g for each Alarm Card required.

Order Code

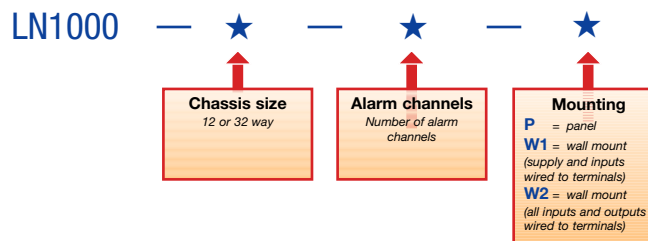

33 – 37 College Street
P.O. Box 145 Gladesville NSW 2111 Australia
Telephone: (61-2) 9816 3377 Fax: (61-2) 9816 3806
Email: admin@measurement-resources.com.au
Website: www.measurement-resources.com.au

LN1000/A/07

