

Averaging Pitot Tube Flowmeter Catalogue

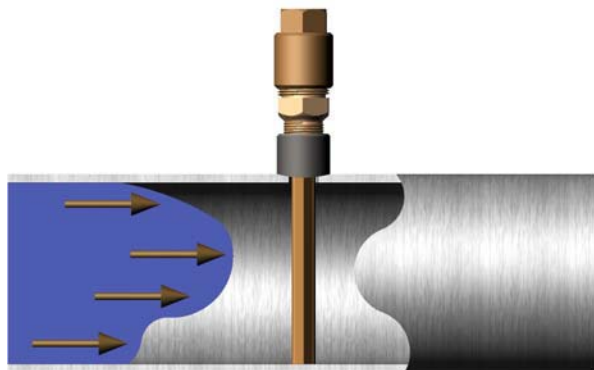

WHAT IS A TORFLOW?

The TORFLOW is a multiport self-averaging flow meter with a design based on the classical pitot tube concept of fluid flow measurement.

Since the introduction of the TORFLOW in 1985, thousands have been installed into a wide variety of industries world wide.

A comprehensive list of major projects and letters of reference from international companies are available on request.

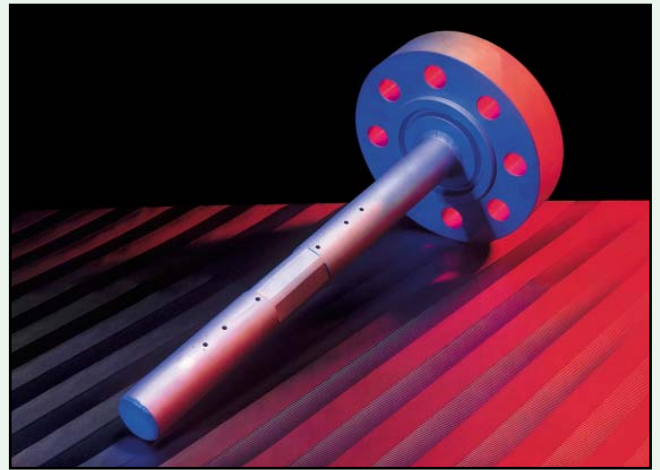

HOW TORFLOW WORKS

TORFLOW produces an averaged differential pressure (DP) signal proportional to the square of the flow rate.

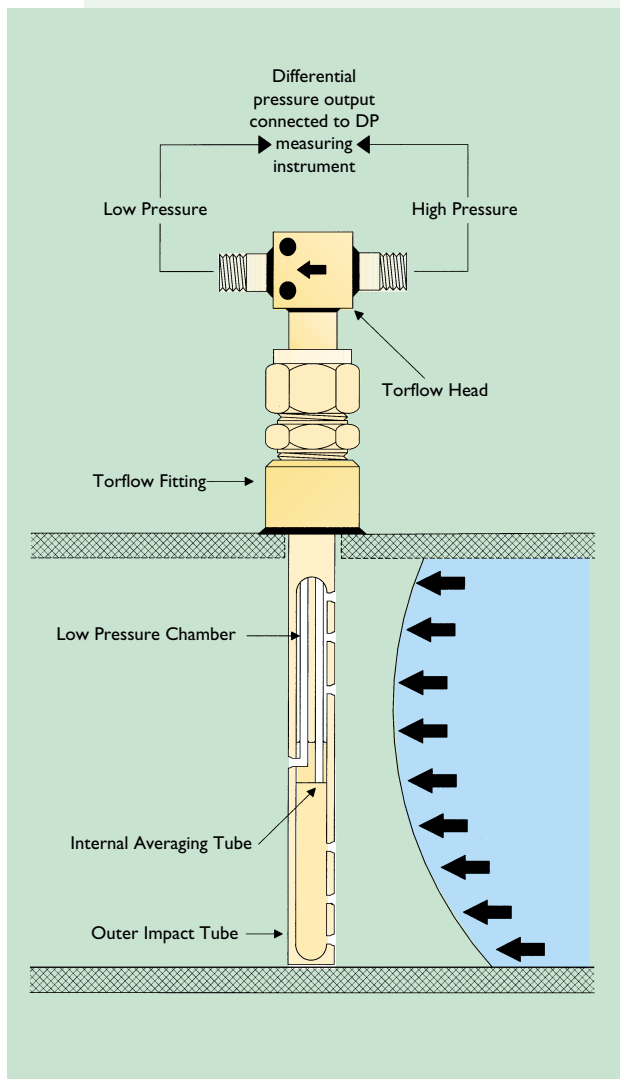

The DP output is normally piped to a Differential Pressure Transmitter in order to generate an electrical signal proportional to the flow rate. A D.P. gauge or switch can be used to provide local mechanical indication or flow rate switching. For certain applications, the DP Transmitter can be directly mounted on to the TORFLOW via an integral 3 valve manifold.

Each TORFLOW is designed to span the process pipe diameter and comprises four basic components:

- **Outer impact tube - ONE PIECE CONSTRUCTION**
- **Internal averaging tube**
- **Low pressure chamber**
- **Head**

The outer impact tube has a number of pressure sensing holes facing upstream which are positioned at equal annular points in accordance with a log-linear distribution.

The "total pressures" developed at each upstream hole by the impact of the flowing medium are firstly averaged within the outer impact tube and then to a second order (and more accurately) averaged within the internal averaging tube. This pressure is represented at the head as the high pressure component of the DP output.

The low pressure component is generated from a single sensing hole located on the downstream side of the outer impact tube. For bi-directional flow measurement, the TORFLOW can be supplied with the same number of downstream ports as upstream. Bi-directional sensors have an inherently lower mechanical strength than the standard TORFLOW (refer factory).

PROFILE SHAPE - The TORFLOW is an improvement on the round sensor design due to the unique profiled flats which are positioned around the downstream hole in order to define the separation point at which the flow lines "break-off" as the fluid passes around the outer impact tube. This feature creates a stable pressure area at the downstream pressure sensing hole thereby maintaining a more constant flow co-efficient K at high velocities enabling a very wide range of flow measurement (turndown).

PROBLEM FLUIDS

The TORFLOW is NOT suitable for the measurement of 2 phase fluids or when the fluid does not completely fill the cross section of the pipe.

Satisfactory flow measurement can be achieved for certain contaminated gas flows (such as flue gas) by using an air purging system. For water flows which may contain a small amount of air, an air-venting package is recommended.

PROFILE SHAPE

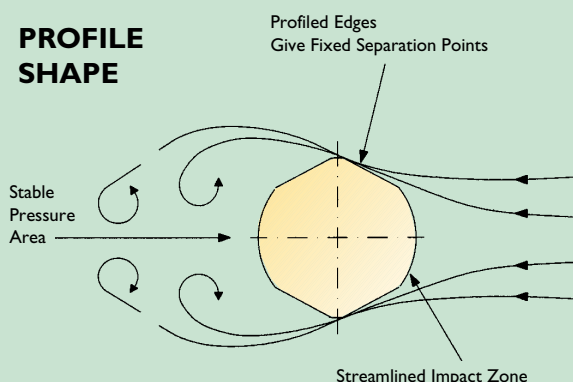

FEATURES

- Unique profile shape enables high flow turndown
- Dual averaging for better accuracy
- One-piece outer tube for optimum strength
- Suitable for pipe sizes from 10mm to 5000mm (and larger with a special 2 piece construction)
- Suitable for square or rectangular section ducts
- Available as hot-tap for insertion into pressurised pipes
- Optional direct mounting transmitter arrangement
- Zero co-efficient drift ensures long term stability
- Low permanent pressure loss means low energy consumption - and significant cost benefits



GENERAL SPECIFICATIONS

- TORFLOW is suitable for liquid, gas, and steam flow measurement
- Accuracy $\pm 1\%$ of actual flow rate - verified by independent flow laboratories
- Repeatability of measurement $\pm 0.1\%$
- Reynolds number. Minimum $Re: 1.2 \times 10^4$
- Flow rate turndown typically 10:1 (100:1 of DP)
- Maximum working pressure up to 600 bar
- Maximum working temperature up to 1300 deg. C with selected materials and fittings
- Maximum viscosity 200 cp (mPas)
- Short upstream and downstream straight pipe lengths
- Long term accuracy unaffected by wear

CONSTRUCTION

- TORFLOWS are engineered and manufactured to stringent routines including BS, ANSI, ASME, ISO and DIN standards
- Welding is carried out by Lloyds qualified welders to ASME IX and European standards.
- Quality control system is approved to BS EN ISO 9002-1994
- TORFLOWS are leak tested before dispatch.
- Hydrostatic pressure testing and NDE is available by request for all models.
- Standard material of construction is 316L stainless steel but many other materials are available on request.
- All TORFLOWS have full material traceability.
- Material test certificates to EN 10204 (DIN 50049) and certificates of conformity are available for each component part of every TORFLOW
- Stainless steel data plate as standard.



INDEPENDENT FLOW TESTS

The TORFLOW accuracy and repeatability of measurement has been verified by independent testing laboratories.

PERMANENTLY INSTALLED TYPES

MODEL SPECIFICATION

IN LINE FITTING

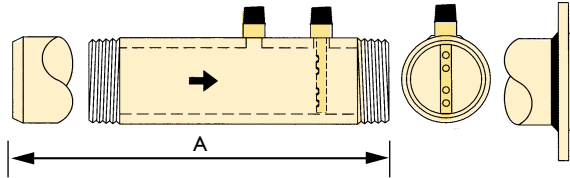

BASIC MODEL	END FITTINGS	FITS PIPE SIZES (mm)
121	Butt Weld	13 - 50
122	Threaded	
123	Flanged	

All models are supplied with a pipe section in the same material as **TORFLOW** probe

PIPE SIZE (INS.SCH80)	'A' (mm)	MODEL	MAXIMUM PRESSURE/TEMPERATURE
1/2"	200	121	200BAR/450°C
1"	225	122	70BAR/200°C
1 1/2", 2"	250	123	As flange rating

THREADED FITTING

BASIC MODEL	D (mm)	FITS PIPE SIZES (mm)
301	13	50 - 150
401†	25	100 - 1800
402*	25	100 - 5000

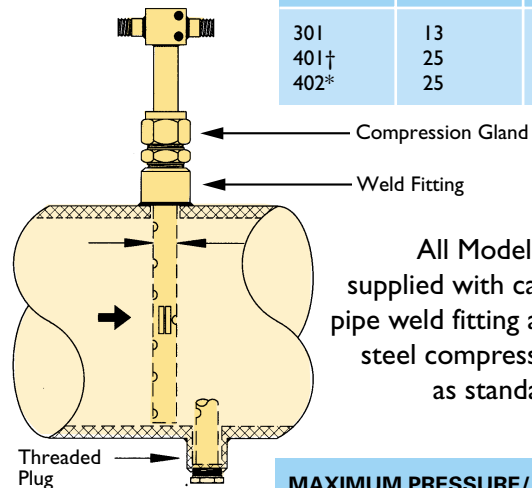

All Models are supplied with carbon steel pipe weld fitting and stainless steel compression gland as standard.

Threaded Plug
End Support Model 402

MAXIMUM PRESSURE/TEMPERATURE

Model 301	70 Bar @ 500°C
Model 401, 402	70 Bar @ 500°C

† For liquid flow applications where there is a possibility of process pulsations or intermittent excessive flow velocity, the end-support model should always be selected for pipe sizes over 250mm internal diameter.

* With end support

FLANGED FITTING

Standard

BASIC MODEL	D (mm)	FITS PIPE SIZES (mm)
311	13	50 - 150
411†	25	100 - 1800
412*	25	100 - 5000

All Models are standardly supplied without flanged pipe fitting or stud bolts and gaskets. These are available as accessories

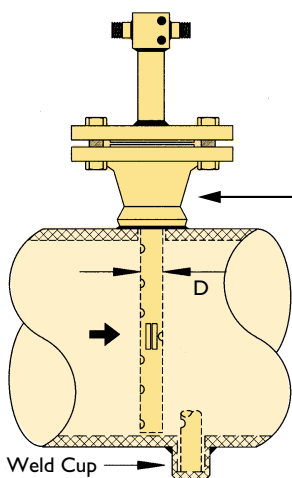

End Support Model 412

STANDARD FLANGE SIZE

Model 311	1 inch (DN 25)
Model 411, 412	1 1/2 inch (DN 40)
(Other sizes available)	

MAXIMUM PRESSURE/TEMPERATURE

ALL MODELS AS FLANGE RATING TO 450°C FOR MATERIAL 316LSS

† For liquid flow applications where there is a possibility of process pulsations or intermittent excessive flow velocity, the end-support model should always be selected for pipe sizes over 250mm internal diameter.

* With end support

FLANGED FITTING

Extra Strength

BASIC MODEL	D (mm)	FITS PIPE SIZES (mm)
511†	60	250 - 1800
512*	60	400 - 8000

All Models are standardly supplied without flanged pipe fitting or stud bolts and gaskets. These are available as accessories

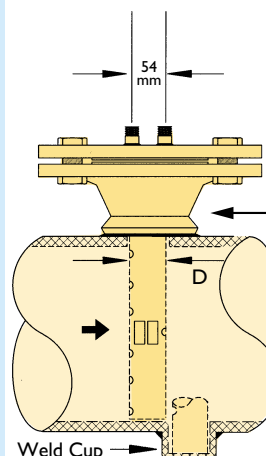

End Support Model 512

STANDARD FLANGE SIZE

Model 511, 512	3 inch (DN 80)
Other sizes available	

MAXIMUM PRESSURE/TEMPERATURE

ALL MODELS AS FLANGE RATING TO 450°C FOR 316L SS

† For liquid flow applications where there is a possibility of process pulsations or intermittent excessive flow velocity, the end-support model should always be selected for pipe sizes over 600mm internal diameter.

* With end support

FOR VERTICAL PIPE INSTALLATIONS - REFER FACTORY

PERMANENTLY INSTALLED TYPES

MODEL CODING

XXX - XXX - XX - 00 - XX - XXX - XXX - XXX

BASIC MODEL

(See opposite page)

NOMINAL PIPE SIZE

TORFLOW PROBE MATERIAL

(see OPTIONS below)

ACCESSORIES

FLANGE SIZE & RATING
(Models 123, 311, 411, 412, 511, 512)

DP OUTPUT CONNECTION
(see below)

PIPE FITTING MATERIAL
(see OPTIONS below)

OPTIONS

PROBE MATERIAL

316L Stainless steel
304 Stainless steel
Monel 400
Hastelloy
6MO
Duplex
Super Duplex
Plastic
Titanium GR2
Other

CODE

SS
4S
ML
HC
6M
DX
SDX
PC
TI
Specify

PIPE FITTINGS MATERIAL

A105 Carbon steel
316L Stainless steel
304L Stainless steel
Monel 400
Hastelloy
6MO
Duplex
Super Duplex
Other
Purchaser Supply

CODE

CS
SS
4S
ML
HC
6M
DX
SDX
Specify
XX

DP OUTPUT CONNECTIONS

X X X

VALVE MATERIAL

No valves
DM or DM3V HEAD
Brass
Carbon Steel
316L Stainless Steel
Monel 400 (Or Alloy 400)
UNS 31254 (6MO)
Hastelloy (C276)
Other

CODE

O
O
B
C
S
ML
6M
HC
SPECIFY

VALVE TYPE

No valves
DM or DM3V HEAD
Ball
Needle
Needle (High Temp)
Gate
Globe
Double Block/Bleed

CODE

O
O
B
V
VH
G
L
VD

SIZE

DM or DM3V HEAD
(See Accessories page 8)
1/4" NPT (M)
1/4" BSPT (M)
1/2" NPT (M)
1/2" BSPT (M)
1/2" WELD (MALE)
1/2" FLANGED
OTHER

CODE

0
3
4
7
8
6
9
SPECIFY

NOTE: For a female output connection WITHOUT valves, add 'F' to size-code. eg: 1/4" NPT female connection without valves, code is 003F.

MALE WITHOUT VALVES

Code Example:
007 (1/2" NPT)

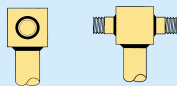

FEMALE WITHOUT VALVES

Code Example:
006F (1/2" Weld Socket)

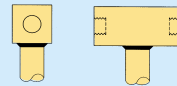

FLANGED WITHOUT VALVES

Code Example:
009 (1/2")

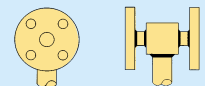

WITH NEEDLE VALVES

Code Example:
SV4
(ST. ST. 1/4" BSPT)

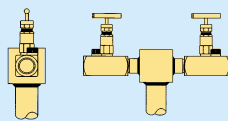

WITH BALL VALVES

Code Example:
BB3
(BRASS. 1/4" NPT)

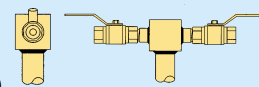

WITH GATE VALVES

Code Example:
CG8
(Carbon ST. 1/4" BSPT)

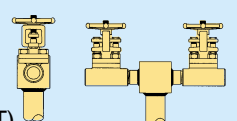

DIRECT MOUNT HEAD

Code: 000
Specify
Accessory: DM



DIRECT MOUNTING WITH MANIFOLD

Code: 000
Specify Accessory: 3VDM (3 Valve)
5VDM (5 Valve)

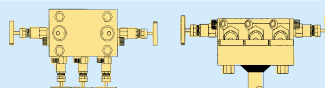

DIRECT MOUNT INTEGRAL MANIFOLD

Code: 000
Specify
Accessory: DM3V

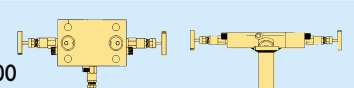

WITHDRAWABLE TYPES (HOT TAP)

MODEL SELECTION

THREADED FITTING

LOW PRESSURE

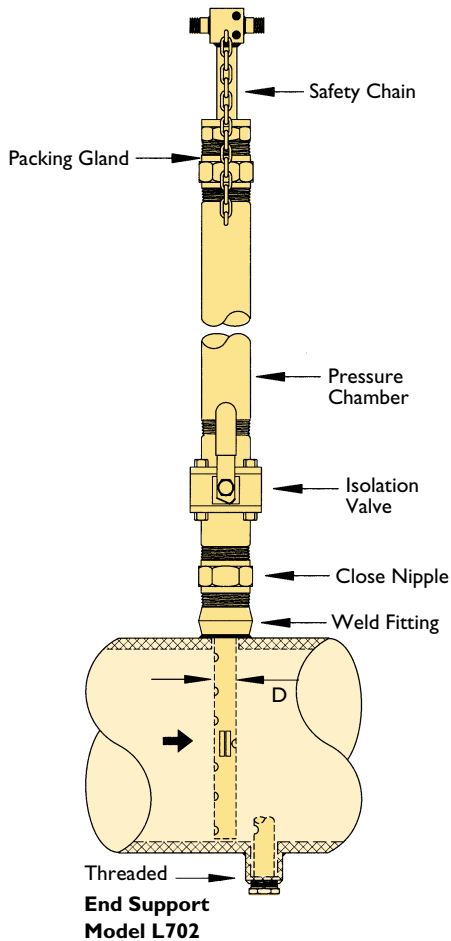

THREADED FITTING

HIGH PRESSURE

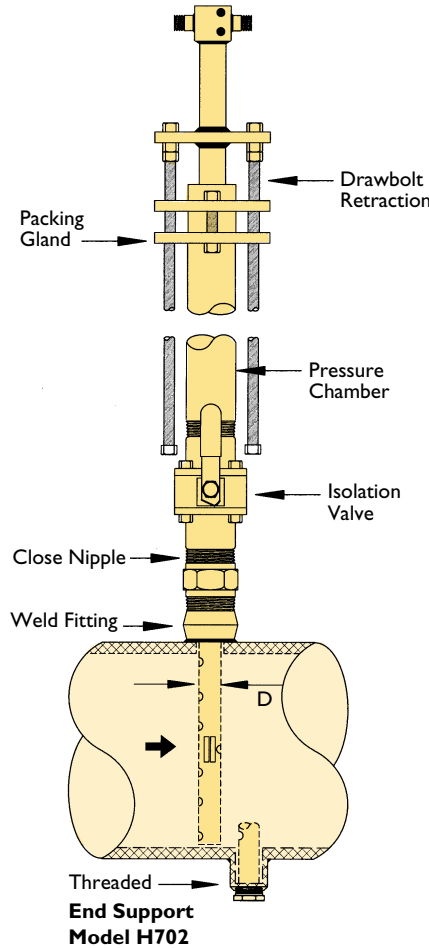

FLANGED FITTING

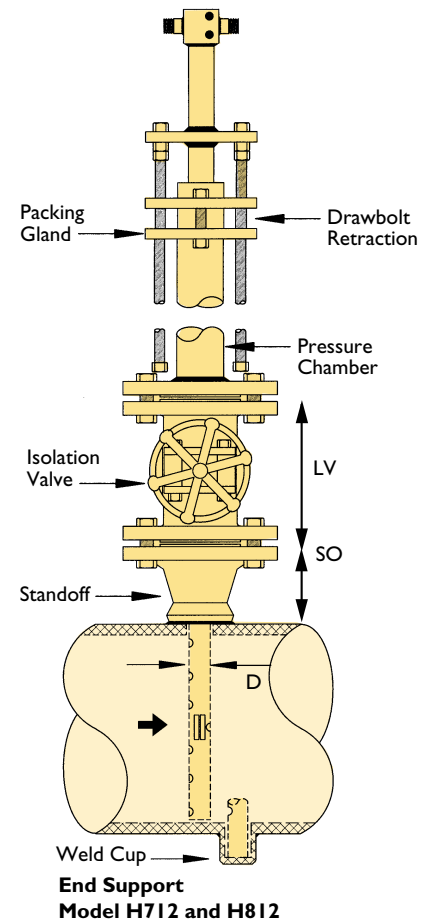

Models L702, H702, H712 and H812 should not be installed into a pressurised pipe because of the requirement to fit an end support. Refer to detailed installation instructions.

BASIC MODEL	D (mm)	FITS PIPE SIZES (mm)
L601	13	50 - 100
L701†	25	100 - 1800
L702*	25	300 - 3000

Supplied with weld fittings, isolation valve and pressure chamber with safety chain as standard. Gland packing material is standardly supplied as non-asbestos graphite ribbon. Teflon is available. Please specify at time of order.

MAXIMUM PRESSURE / TEMPERATURE

With standard ball valve 10 bar and 200°C
With standard gate valve 10 bar and 450°C
(Temperature is at valve)

† For liquid flow applications where there is a possibility of process pulsations or intermittent excessive flow velocity, the end-support model should always be selected for pipe sizes over 250mm internal diameter.

*with end support

BASIC MODEL	D (mm)	FITS PIPE SIZES (mm)
H601	13	050 - 100
H701†	25	100 - 1800
H702*	25	300 - 3000

Supplied with weld fittings, isolation valve, pressure chamber and draw bolt retraction (illustrated) as standard. Gland packing material is standardly supplied as non-asbestos graphite ribbon. Teflon is available. Please specify at time of order. Geared retraction - optional.

MAXIMUM PRESSURE / TEMPERATURE

With standard ball valve 40 bar and 200°C
With standard gate valve 40 bar and 450°C
(Temperature is at valve)

† For liquid flow applications where there is a possibility of process pulsations or intermittent excessive flow velocity, the end-support model should always be selected for pipe sizes over 250mm internal diameter.

*with end support

BASIC MODEL	D (mm)	FITS PIPE SIZES (mm)	STANDARD FLANGE SIZE
H611	13	50 - 100	1"(DN25)
H711†	25	100 - 1800	1½"(DN40)
H712*	25	300 - 3000	1½"(DN40)
H811†	60	300 - 2000	3"(DN80)
H812*	60	600 - 3000	3"(DN80)

other sizes available

Supplied with isolation valve and pressure chamber, and draw bolt retraction assembly and without flanged pipe fitting or stud bolts and gasket (Available as accessories). Gland packing material is standardly supplied as non-asbestos graphite ribbon. Teflon is available. Please specify at time of order. Geared retraction - Optional.

MAXIMUM PRESSURE / TEMPERATURE

With standard ball valve 100 bar and 200°C
With standard gate valve 100 bar and 450°C
(Temperature is at valve)

† For liquid flow applications where there is a possibility of process pulsations or intermittent excessive flow velocity, the end-support model should always be selected for pipe sizes over 600mm internal diameter.

*with end support

FOR VERTICAL PIPE INSTALLATIONS - REFER FACTORY

WITHDRAWABLE TYPES (HOT TAP)

MODEL CODING

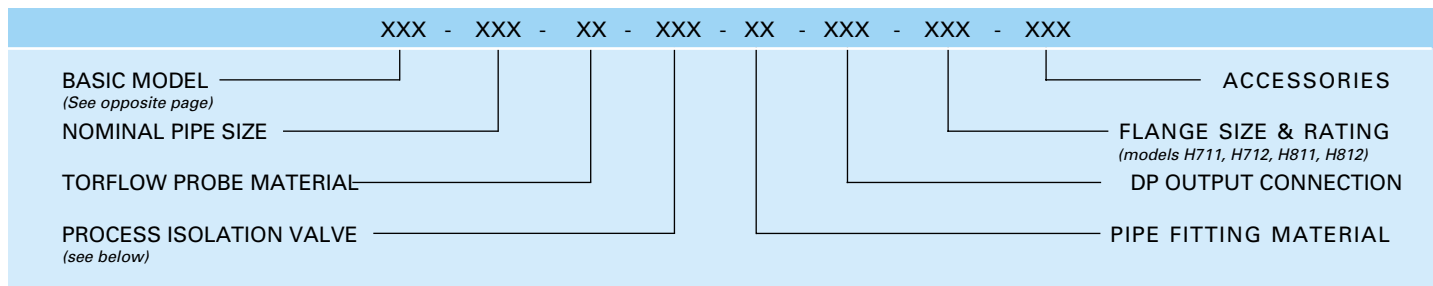

PROCESS ISOLATION VALVES

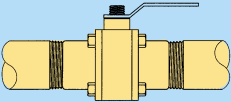
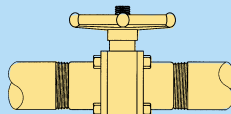
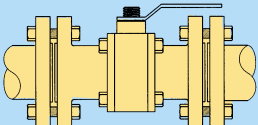
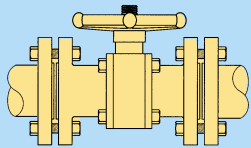
VALVE TYPE	TORFLOW MODEL	VALVE SIZE	CODE (* IS MATERIAL SEE BELOW)	MAXIMUM TEMPERATURE AT VALVE
Threaded Ball 	L601	3/4" BSPT	5B*	200°C
	L701 L702 H701 H702	1 1/4" BSPT	7B*	200°C
Threaded Gate 	L701 L702 H701 H702	1 1/4" BSPT	7G*	450°C
Flanged Ball 	H611	1"	4B*	200°C
	H711	1 1/2"	8B*	200°C
	H712	2"	6B*	200°C
	H811 H812	3"	9B*	200°C
Flanged Gate 	H611	1"	4G*	450°C
	H711	1 1/2"	8G*	450°C
	H712	2"	6G*	450°C
	H811 H812	3"	9G*	450°C

Code * defines valve material

**316SS - (S) CARBON STEEL - (C) MONEL - (M) FOR OTHER MATERIAL SPECIFY
(EXAMPLE: 7GC IS 1 1/4" BSPT GATE VALVE IN CARBON STEEL).
WHEN VALVE IS SUPPLIED BY PURCHASER, WHOLE CODE IS: XXX.**

APPLICATIONS

Thousands of **TORFLOWS** have been successfully used on a large variety of flow applications throughout the world by many different industries, such as:

- OIL PRODUCTION
(ONSHORE, OFFSHORE)
- OIL REFINING
- CHEMICAL
- PHARMACEUTICAL
- POWER GENERATION
- BUILDING SERVICES
- H V A C
- NUCLEAR
- FOOD
- WATER DISTRIBUTION
- WATER TREATMENT
- EFFLUENT TREATMENT
- GAS PROCESSING
- GAS TRANSMISSION
- etc. etc.



Applications where TORFLOWS have been used successfully were for the flow measurement of:

- NATURAL GAS
- FLUE GAS
- NITROGEN GAS
- HYDROCARBON GAS
- METHANE GAS
- COMBUSTION GAS
- SOUR GAS
- EXHAUST GAS
- COKE OVEN GAS
- CARBON DIOXIDE GAS
- PETROL VAPOUR
- VENTILATION AIR
- COMPRESSED AIR
- HOT AIR
- SOLVENT LADEN AIR
- SATURATED AIR
-
- SATURATED STEAM
- SUPERHEATED STEAM
- SEA WATER
- COOLING WATER
- RIVER WATER
- WASTE WATER
- POTABLE WATER
- LIQUID OXYGEN
- CRUDE OIL
- NITRIC ACID
- RED WINE
- LIQUID PETROLEUM
- and many other...



13 Sirius Road, Lane Cove NSW 2066 Australia
 Tel: +61 (0)2 9428 7377
 Fax: +61 (0)2 9428 7379
 Email: Sydney@hmagroup.com.au
 Website: www.measurement-resources.com.au

APTF/A/07



PRINTED IN AUSTRALIA