

SERIES 454FTB

SINGLE-POINT INSERTION
THERMAL MASS FLOW
TRANSMITTERS



Timelines

HMA

**MEASUREMENT
RESOURCES**



DESCRIPTION

The Series 454FTB represents the Kurz family of state-of-the-art microprocessor based, industrial quality, Single-Point Insertion Mass Flow Transmitters for industrial gases. It has many improvements and features that greatly enhance the performance, including, the new FD2-HT Sensor rated at 260°C, electronic self-check functions, a flow control valve PID controller, a Patented digital thermal anemometer bridge, a more convenient remote electronic mounting configuration, a one-piece PCB for improved reliability and ease-of-use, built-in sensor cleaning purge timer, external inputs/outputs, and many other Kurz engineering and functional features. The 454FTB includes the most advanced temperature compensation, microprocessor technology and the highest repeatability, accuracy, and reliability available. The 454FTB has CE Compliance and a Canadian Registration Number for most applications. The 454FTB meets CSA (USA and Canada), IECEx and ATEX Non-Incendive and Explosion-Proof/Flame-Proof Safety Standards and are IP66/NEMA 4X/7 Rated. Kurz is an ISO 9001 Quality Manufacturer.

KEY FEATURES

- Constant temperature sensor control circuit.
- Sensors and Electronics (single PCB) are interchangeable. No matched sets.
- 3 Year Warranty. All components pass an extensive accelerated stress test for high reliability.
- Velocity dependent correction factors for Flow Rate.
- Zero velocity is a valid data point.
- Fastest response to temperature and velocity changes in the industry.
- Velocity/Temperature/Mapping (VTM) for wide ranging velocity and temperature.
- Process Temperature Rating of -40°C to +260°C (HT) or -40°C to +500°C (HHT).
- Electronics operating temperature range of -40°C to +65°C, non-condensing.
- Process Pressure Rating up to 300 PSIG.
- Velocity range of 0-24,000 SFPM (112 NMPS).
- Easy-to-use menus for display and configuration including basic setup "Wizard".
- User configurable scrolling or static displays of flow process variables.
- Configuration upload/download software using a PC with USB connection, RS-485 or TCP/IP Modbus.
- Adjustable LCD/Keypad orientation allows viewing of the display for horizontal or vertical installations.
- User selected English or Metric units (SFPM, SCFM, SCFH, PPM, PPH, °F; SMPS, NMPS, NLPM, NCMH, SLPM, SCMH, KGM, KGH, °C).
- USB port for terminal operation.
- Modbus ASCII or RTU communications.
- HART 7 communication option.
- Alloy C-276 all-welded sensor construction.
- Integral or Remote Electronics Enclosure.
- IP66/NEMA 4X/7 dual chamber epoxy painted electronics enclosure.
- Input power options of 85 to 265 VAC 47/63 Hz or 24 VDC.
- Two optically isolated loop-powered 4-20 mA outputs which are user configurable. Typically, one is configured for mass flow rate or mass velocity and the other for process temperature or for PID application (Flow transmitters with the HART communication option have only one 4-20mA output).
- Two optically isolated solid-state alarm/relays (optional).
- Two digital inputs dedicated to Purge and Zero-MidSpan-Span Drift Check (optional).
- One 4-20mA input (optional).
- PID Flow Controller.
- Built-in Zero-MidSpan-Span CEMS electronics drift check circuits.

- Meets EPA Mandatory GHG Certification Requirement in CFR98.34(c)(1).
- 4-20 mA outputs meet NAMUR NE43 recommendations.
- User programmable Access Codes.
- User may change STP reference condition without affecting factory calibration data.
- Automatic Sensor Blockage Correction Factor (SBCF).
- Pulsed output for use as a remote flow totalizer (optional).
- Sensor lead length independent circuitry.
- User-selectable digital filtering.
- Programmable alarm functions.
- Built-in flow totalizers and elapsed time.
- Insensitive to orientation.
- Optional Air Purge Sensor Cleaning System.
- Built-in purge timer and "hold value" feature during purge for use with Model 146 Sensor Cleaning System.
- CE Compliance including EMC, ATEX, LVD, PED, WEEE and ROHS EU Directives.
- Non-Incendive and Explosion-Proof/Flame-Proof Safety Approvals (CSA/ATEX/IECEx).

APPLICATIONS

- Industrial and process gas mass flows
- Combustion air flow measurements
- EPA Flow Monitors
- Flare stack metering
- Aeration air flow and digester off-gas flow
- Landfill vapor recovery
- Incinerator stack mass flow
- Solvent recovery system mass flow
- VOC mass flow
- Cement plants
- Coal-fired boiler combustion air
- Compressed air
- Natural gas, and most industrial gases
- Semi-conductor processing gas metering
- Nuclear power plants
- Air sampling in D.O.E. facilities
- O.E.M. applications

OUR MISSION

To manufacture and market the best thermal mass flow meters available and to support our customers in their efforts to improve their business.

SERIES 454FTB SINGLE-POINT INSERTION THERMAL MASS FLOW TRANSMITTERS

PRINCIPLE OF OPERATION

The Series 454FTB uses the well-recognized Kurz thermal convection mass flow measurement method by detecting the heat transfer from the heated RTD sensor (Rp) referenced to the temperature of the ambient gas stream RTD sensor (Rtc). A constant temperature difference between the heated sensor and the temperature sensor is maintained with a Patented digital control circuit providing unexcelled speed of response and the many other advantages of constant temperature thermal anemometry. The microprocessor-based electronics measures the heat transfer, computes the standard velocity and ambient gas temperature, and allows the user to configure and set-up the 454FTB to fit all flow requirements. Display screens are easy-to-use and provide all the flow and temperature and diagnostic information. For a more detailed description of Kurz technology, please see Document Number 364003, "Theory and Application of Kurz Thermal Convection Mass Flow Meters" by contacting the Kurz Factory or by visiting our web site.



Figure 1—Series 454FTB LCD/Keypad with Lid Removed.



Figure 2—Fast Dual (FD2) Sensor.

CALIBRATION CURVE

Figure 3—The basic flow calibration curve is non-linear, having a non-zero output (live zero) at zero flow and a nearly constant percent of reading accuracy. Zero is a valid data point for a Kurz meter. The 454FTB electronics linearizes this non-linear Calibration Data.

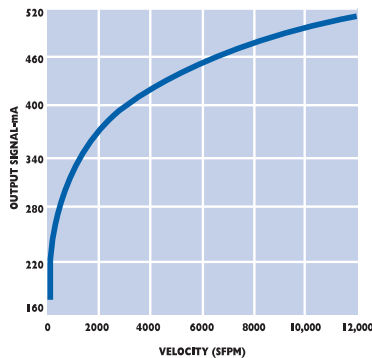

Figure 3—Calibration Curve.

TIME RESPONSE TO FLOW AND TEMPERATURE CHANGES

Figure 4—Shows the response of a Kurz Fast Dual (FD2) MetalClad™ sensor to a step change in velocity. Kurz manufactures the fastest industrial quality sensors available.

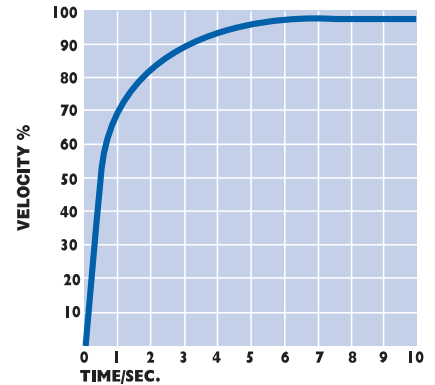

Figure 4—Sensor Flow Response.

Figure 5—Shows a typical response to a step change in temperature for a Kurz Fast Dual (FD2) MetalClad™ sensor. It is exceptional and allows use of the sensor for combustion air flow measurements in boilers that mix hot and cold air for temperature control in coal pulverizers, for example.

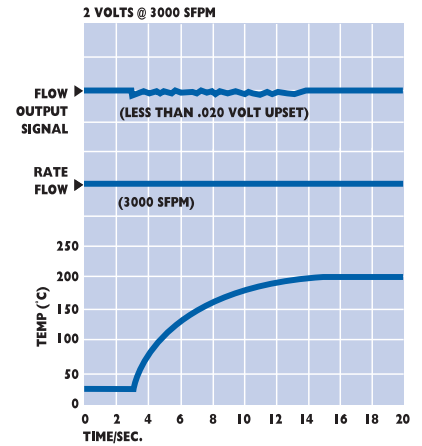

Figure 5—Sensor Temperature Response.

ORIENTATION EFFECTS

Figure 6—Shows a typical output response to changes in the incoming velocity direction. Data is shown for rotation and yaw, as defined by Figure 7. Note that the effect is small for angles up to ± 20 degrees. This is extremely important for flow applications having severe turbulence and a non-axial velocity direction.

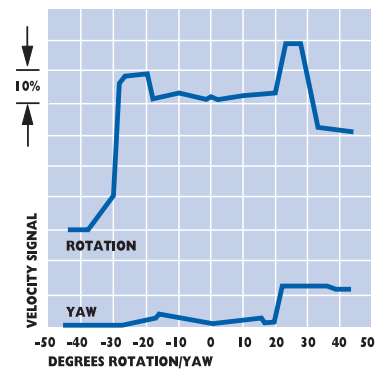

Figure 6—Sensor Measurement Error Versus Rotation/Yaw Angles.

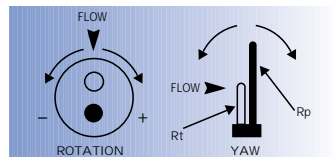

Figure 7—Sensor Rotation and Yaw Description.

SPECIFICATIONS

Process Temperature Rating:
HT(-40°C to 260°C)
HHT(-40°C to 500°C)

Process Pressure Rating:
300 PSIG (20 BARg)

Sensor Material: Alloy C-276;
optional abrasion-resistant
Chromium Nitride coating on
Alloy C-276 sensor materials.
PTFE coating for chemical
resistance on Alloy C-276
sensor and sensor support,
HHT sensors, 260°C max.

Sensor Support Material:
316L Stainless Steel, optional
Alloy C-276.

Repeatability: 0.25%

Velocity Time Constant:
1 second for velocity changes
at 6000 SFPM at a constant
temperature and 1 second for
temperature changes at a con-
stant velocity of 6000 SFPM.

**Process Temperature
Time Constant:**
8 seconds at a velocity of
6000 SFPM.

Velocity Accuracy:
See Feature 4 for overall
accuracy including the effects
of process temperature.

Temperature Accuracy:
±(1/2% of reading +1°C) for
velocities above 100 SFPM.

Power: +24 VDC ±10%, 85-265
VAC, 47/63 Hz; 24 watts max.

**Enclosure Temperature
Rating:** -25°C to +65°C for all
configurations; -40°C to
+65°C for DC units without
LCD/Keypad.

Enclosure: Epoxy-Painted
aluminum, IP66/NEMA 4X/7
with glass window for display
option.

Solid-State Relays:
Optically isolated, 0.5 ampere,
24 VAC/VDC maximum

Analog Outputs (4-20 mA):
Optically isolated, user loop-
powered, 12 bit resolution
and accuracy, maximum loop-
resistance is 300Ω at 18 VDC,
550Ω at 24 VDC, 1400Ω at
36 VDC; meets NAMUR NE43
recommendations.

Meter Filter Time Constant:
Selectable 0 to 600 seconds.

Continued on next page

TECHNICAL DESCRIPTION

SENSOR DESIGN

Series 454FTB Insertion Mass Flow Transmitters use the Kurz MetalClad™ FD2 all-welded Alloy C-276 sensor. In this design, the temperature sensor and velocity sensor are mounted in separate tubes (or “stings”), providing exceptional thermal isolation from the sensor support structure and fast response to process temperature changes.

SENSOR MATERIALS AND CONSTRUCTION

The standard sensor material for all Kurz metal sensors is Alloy C-276. This material is far superior to 316 Stainless Steel in high temperature and corrosive applications. Kurz offers Chromium Nitride coating for abrasive, dirty applications, such as in boiler coal pulverizers. Kurz exclusively uses Inconel sheathed mineral-insulated cable (MI cable) for temperatures above 260°C.

PROCESS TEMPERATURE RATING

Kurz offers sensor process temperature ratings of 260°C and 500°C. Field data verifies that the lifetime at 500°C is at least five years and the lifetime at 260°C is at least 10 years.

TRANSMITTER CONFIGURATIONS

Two configurations are available; Directly Attached Electronics Enclosure and Remote Electronic Enclosure.

PROCESS TEMPERATURE COMPENSATION

The influence of temperature on the thermal properties of gases requires temperature compensation for repeatable and accurate measurements. Standard Temperature Compensation (STC) is used for applications in which the process temperature is below 125°C over a moderate velocity range or below 260°C over a more limited velocity range. If the process temperature and gas velocity vary widely, Velocity/Temperature/Mapping (VTM) is recommended. VTM includes several process temperatures and uses the microprocessor to calculate the velocity based on the built-in process temperature measurement.

GAS CALIBRATION

The customer has a choice of a laboratory calibration or a gas correlation calibration. Air calibrations are performed in the Kurz Model 400D NIST traceable wind tunnel.

SENSOR PROTECTION

The 454FTB circuitry includes circuitry to prevent an over-temperature condition caused by a sensor, wiring or component failure. Our sensors will not overheat at zero flow, unlike most competitive devices because of our constant temperature sensor control method and the power limiting design.

**AIR PURGE SENSOR
CLEANING SYSTEM**

The Model 454PFTB has a special nozzle in the sensor window for use with the Model 146 Air Sensor Cleaning System. The sensor cleaning is accomplished by a short, high pressure blast of air (sonic velocity) directed at the velocity and temperature sensors. Kurz provides solenoid valves and air blow-down tanks to allow periodic or on-demand cleaning. The 454PFTB has a built-in timer and relay to initiate the purge cycle. The measurement value is “held” during the purge cycle. The air blow-down tank uses customer supplied compressed air (instrument quality) at 60 to 125 PSIG. The average cleaning air consumption is less than 0.125 SCFM. The Model 454PFTB is designed to measure air flow only at ambient pressure. Canadian Registration (CRN) is not available for the Model 454PFTB. The primary application is for extremely dirty stacks and ducts having dry particulate matter that may build up on the sensor. Applications include fossil-fueled power boilers, municipal waste incinerators and combustion air flow situations in which fly ash is entrained.

SENSOR ELECTRONICS

The Series 454FTB has several innovations which improve performance, reduce cost and provide extraordinary flexibility. The patented digital sensor control circuit (US Patent 7,418,878) uses an efficient switching power supply. The single-board PCB has an EEPROM loaded with the PCB serial number, calibration coefficients, and component values which insures the safety of the data. The sensor electronics includes a sensor lead resistance compensation circuit which is extremely important for long sensor wires, rapid gas temperature changes and large temperature gradients between the sensor and the ambient air.

SPECIFICATIONS *Cont'd.***Safety Approvals:**

CSA Non-Incendive Approval:
IEC 79-15 and EN60079-0/15

ATEX Non-Incendive Approval:
EN60079-0/15 and EN61241-1

CSA Explosion-Proof Approval:
IEC 79-01 and EN60079-01

ATEX Flame-Proof Safety Approval:
EN 60079-0/1

Note: See Kurz website for the complete Safety Approvals Specifications.

CE Directives:

EMC, ATEX, LVD and PED.
Consult Kurz for details.

Serial Port Baud Rate:

User selectable: 9600, 14,400,
19,200, 38,400, 57,600.

Communication Ports:

RS485 Modbus ASCII or RTU
Mode, and USB.

Digital Inputs:

Two, contact closure, TTL.

Analog Input:

One, 4-20mA, non-isolated.

LCD: Back-lit two-line alphanumeric
with 16 characters per line.

LCD Update: Every two seconds.

Keypad: 20-button membrane
mounted inside enclosure.

LCD/Keypad Orientation:

Adjustable in 90° increments
to accommodate viewing
orientation.

Electronics Enclosure

Orientation: 0° or 180° for viewing
(Feature 1).

Memory:

EEPROM for all important data,
with automatic sensor
identification; Flash EEPROM for
Program Memory.

Net Weight/Shipping Weight: DC

Version: 4lbs/5lbs;
AC Version: 6lbs/8lbs,
add 4lbs/5lbs for remote option.

TECHNICAL DESCRIPTION *Cont'd.***FIRMWARE**

The onboard menu system is easy to use and intuitive. The flow meter data (e.g. velocity, mass rate, volumetric rate, and temperature) can be displayed in a user selectable form and viewed through the window in the lid. A local keypad can be accessed to navigate through the on board menu system to display various flow and diagnostic data as well as enter basic and advanced setup options. A user code is required for programming and entering configuration data or performing test and diagnostic utilities.

SELF-DIAGNOSTICS

The 454FTB performs an extensive systems check upon power-up and continuously monitors the sensor inputs/outputs and verifies the integrity of the sensor wiring and the measurements.

PROGRAMMABLE CORRECTION FACTORS

A multi-point Variable Correction Factor may be used to correct the flow calibration data to meet in-situ flow tests over the entire velocity range such as done for EPA Stack Flow Monitors. A Sensor Blockage Correction Factor (SBCF) can be used to correct for the area reduction caused by the sensor support. A single point Correction Factor may also be used.

METER FILTER TIME CONSTANT

A digital filter time constant may be set for the flow calculation which affects the displayed values and the 4-20 mA outputs. The time constant can be set from 0 to 600 seconds

COMPATIBILITY WITH SERIES 155 MASS FLOW COMPUTERS

The 454FTB is fully compatible with the inputs and features of the Series 155 Mass Flow computer. DC powered units can be directly powered by the 155 Computer. This Feature is used when two or more Model 504FTBs are used in a multi-point velocity array. (Please see the Series 155 brochure).

SELECTABLE STP CONDITIONS

The mass flow calibration data is referenced to the Kurz laboratory standard of 77°F/14.69 PSIA (25° C/101.325 kPa). The user may change the STP conditions to suit his requirement without affecting the calibration data.

4-20 mA OUTPUTS

The 4-20mA outputs may be wired as optically isolated loop-powered outputs or non-isolated, self powered outputs. The user may easily re-calibrate the 4-20 mA outputs using the CALIBRATE ANALOG OUTPUT menu in the onboard menu system or through the HART interface.

NAMUR NE43 COMPLIANCE

Kurz meets the NAMUR NE43 recommendation for the 4-20 mA outputs to indicate a sensor or system fault. An NE43 alarm may be selected as high or low (but not both). This feature frees up the alarm/relays so that the user can set-up the relays for other needs.

BUILT-IN "ZERO-MIDSPAN-SPAN"**DRIFT CHECK/CALIBRATOR**

The B-Series Flow Transmitters have a Drift Check feature that meets the U.S. E.P.A. requirements for CEM Stack Flow Monitors. The MFT B-Series have a built-in independent voltage source that is used to drive the 4-20mA output for the Drift Check Test(s). A Drift Check setup menu is available to configure the signal level and duration for the Drift Checks at Zero, Mid-Span, and Full-Span. The Drift Check(s) can be initiated with a contact closure, through MODBUS command, automatic internal timer, through the HART Interface or the local onboard menu system.

GREENHOUSE GAS REPORTING

Beginning in 2010, the EPA requires certain facilities to report GHG emissions. This rule is contained in US Code of Federal Regulations Title 40, Part 98. Kurz thermal mass flow meters meet the certification requirement in 40 CFR 98.34(c)(1) required by the Mandatory GHG Reporting regulation and are approved for this application.

RELAYS - ALARMS/PULSED TOTALIZER OUTPUT/PURGE OUTPUT

The 454FTB can be ordered with up to 2 solid-state optically isolated relays. The relay outputs can be user configured to the following functions – alarm outputs, pulsed totalizer output, or air purge cleaning. If no relays are ordered, the alarm functions are displayed on the LCD. Totalizers may be automatically reset at a specific total quantity (i.e., 10,000 SCF).

SERIES 454FTB SINGLE-POINT INSERTION THERMAL MASS FLOW TRANSMITTERS

TECHNICAL DESCRIPTION Cont'd.

ANALOG INPUT

One non-isolated 4-20mA input for use as a remote set-point for the built-in PID Flow Controller.

PID FLOW CONTROLLER

The 454FTB includes the capability of controlling the velocity or flow rate through the use of the user's control valve, damper or position commanded 4-20 mA interface device. The Set-Point may be internal or remote.

USB PORT

A USB port for terminal operations includes a COM emulator driver which can be accessed using a PC terminal emulator program to remotely "echo" the LCD and keypad functions and upload/download the system configuration and calibration data files using XMODEM protocol. Process data may be initiated manually through the Log Mode menu from the remote terminal/keyboard or the local LCD/keypad. The information may also be obtained automatically by configuring the Serial Data Logging through the onboard menu system.

HART

The Series 454FTB can be ordered with the HART communication interface. The HART protocol is a recognized and accepted standard in the process control industry. This interface provides the following benefits with the Series 454FTB – remote configuration, remote diagnostic monitoring, and the ability to do testing on-line using available hand held configurators.

MODBUS

The Modbus local network protocol (ASCII or RTU) is included. The use of Modbus is extremely useful, as most features may be accessed, including configuration upload, download, etc.

ORDERING INFORMATION

FLOW TRANSMITTER SELECTION

Table 1 lists the Series 454FTB Model number, Parent Number and Major Features. **Table 2** lists the Baseline (V*) Full Scale Velocity for each Gas Type. **Table 3** lists the Flow factor (F*) Equation for each Gas Type.

Model Number	Parent Number	Sensor Support Dia.	Process Temp. Rating	Air Purge	Safety Approvals
454FTB-08-HT	756051	½"	HT	No	NI, XP/FP
454FTB-08-HHT	756052	½"	HHT	No	NI, XP/FP
454FTB-12-HT	756053	¾"	HT	No	NI, XP/FP
454FTB-12-HHT	756054	¾"	HHT	No	NI, XP/FP
454FTB-16-HT	756055	1"	HT	No	NI, XP/FP
454FTB-16-HHT	756056	1"	HHT	No	NI, XP/FP
454PFTB-16-HT	756057	1"	HT	Yes	NI, XP/FP
454PFTB-16-HHT	756058	1"	HHT	Yes	NI, XP/FP

Model Number	VELOCITY SFPM (NMPS)					
	Gas Category and Gas Type					
	1 Air, N ₂ , O ₂ , Ar, CO ₂ , Dry Cl ₂	2 Methane Digester Gas, Dry Ammonia	3 Ethylene	4 Ethane	5 Helium, Propane Butane	6 Hydrogen
454FTB-08-HT 454FTB-12-HT 454FTB-16-HT To 125°C	18,000 (84)	17,000 (79)	15,000 (70)	13,300 (62)	10,000 (47)	6,000 (28)
454FTB-08-HT 454FTB-12-HT 454FTB-16-HT 454PFTB-16-HT To 260°C	18,000 (84)	N/A	N/A	N/A	N/A	N/A
454FTB-08-HHT 454FTB-12-HHT 454FTB-16-HHT 454PFTB-16-HHT To 500°C	18,000 (84)	N/A	N/A	N/A	N/A	N/A

Note 1: See Nomenclature for the complete definition of Gas Group Number and Gas Type.

Note 2: SFPM: Standard Feet-Per-Minute (Ref.: 77°F, 14.69 PSIA).

NMPS: Normal Meters-Per-Second (Ref.: 0°C, 760 mm Hg).

NMPS = 0.00466 x SFPM (Approximate).

Note 3: The Baseline (V*) VELOCITY for each Mass Flow Transmitter Model Number and for each type of Gas is the maximum velocity at standard conditions (See Note 2).

Gas	DR _p	Equations
Category 1: Air, N ₂ , Ar, CO ₂ , O ₂ , Dry Cl ₂	Less than 1.333	F* = DR _p
	Greater than 1.333	F* = 1.333
Category 2: Methane, Digester Gas, Dry Ammonia	Less than 0.945	F* = 1.059DR _p
	Greater than 0.945	F* = 1.000
Category 3: Ethylene	Less than 0.833	F* = 1.2DR _p
	Greater than 0.833	F* = 1.0
Category 4: Ethane	Less than 0.739	F* = 1.353DR _p
	Greater than 0.739	F* = 1.000
Category 5: Helium, Propane, Butane	Less than 0.555	F* = 1.8DR _p
	Greater than 0.555	F* = 1.000
Category 6: Hydrogen	Less than 0.333	F* = 3.0DR _p
	Greater than 0.333	F* = 1.000

SERIES 454FTB SINGLE-POINT INSERTION THERMAL MASS FLOW TRANSMITTERS

NOMENCLATURE:

PROCESS TEMPERATURE RATING		
Identifier	Description	Range
HT	High Temperature	-40°F to 500°F (-40°C to 260°C)
HHT	Very High Temperature	-40°F to 932°F (-40°C to 500°C)

SENSOR TYPE	
Identifier	Description
FD2	Fast Dual Metal-Clad™ Velocity and Temperature Sensor, all-welded construction, 0.105" diameter sensor stings

SAFETY APPROVALS	
Identifier	Description
NI	Non-Incendive, CSA and ATEX
XP/FP	Explosion-Proof/Flame-Proof, CSA and ATEX

GAS CATEGORY AND GAS TYPE	
Category	Gas Type
1	Air, Nitrogen, Oxygen, Argon, Carbon Dioxide, Dry Chlorine
2	Methane, Digester Gas, Dry Ammonia
3	Ethylene
4	Ethane
5	Helium, Propane, Butane
6	Hydrogen

DEFINITIONS FOR THE USE OF TABLES 1, 2, 3

Equation 1: $DR_p = \frac{P_p}{P_s} \times \frac{T_s}{T_p}$

Equation 2: $V_{MAX} = F^* \times V^*$

V^* = Baseline Velocity as listed in Table 2 (SFPM for English Units or NMPS for Metric Units at Standard conditions).

V_p = Process Velocity (SFPM for English Units, NMPS for Metric Units).

V_{MAX} = Maximum Velocity for a specific Gas Type under Process Conditions.

F^* = Flow Factor (see table 3).

T_s = Standard Absolute Temperature: 537°R (77°F + 460) for English Units or 273°K (0°C) for Metric Units.

T_p = Process Absolute Temperature: °R (T°F + 460) for English Units or °K (T°C + 273°C) for Metric Units.

P_s = Standard Absolute Pressure (14.69 PSIA for English Units and 760mm Hg for Metric Units).

P_p = Process Absolute Pressure (PSIA for English Units and mm Hg for Metric Units).

DR_p = Process Gas Density Ratio.

Example: Calculate the maximum allowable Gas Velocity (V_{MAX}) for compressed air at 100°F and 135 PSIA for the Model 454FTB-12-HT.

a) From **Table 2**, $V^* = 18,000$ SFPM

b) Calculate DR_p from Equation 1:

$$DR_p = \frac{P_p}{P_s} \times \frac{T_s}{T_p} = \frac{135}{14.69} \times \frac{537}{560} = 8.81$$

c) Using **Table 3** for Category 1, Air: $F^* = 1.333$ (DR_p greater than 1.333)

d) Using Equation 2: $V_{MAX} = F^* \times V^* = 23,944$ SFPM (111.8 NMPS)

Part Number Generation Procedure

With the selected Parent Number, specify the entire Part Number by selecting an Option for each Feature as shown in the example below. Feature Options in Bold type indicate the most available Models, other options usually require a longer delivery time.

Example Part Number for a Model 454FTB-16-HHT:

756056 **D** **32** **F** **4** **F** **077** **M** **01** **A** **015** **B** **1392**

Parent Number F1 F2 F3 F4 F5 F6 F7 F8 F9 F10 F11 F12

SUMMARY OF FEATURES	
Feature	Feature Description
1	Electronics Enclosure Configuration and Input Power, LCD/Keypad
2	Sensor Material/Sensor Support and Flange Material
3	Sensor Support Length
4	Process Temperature Compensation
5	Optional Flange Connection Size and Rating
6	Optional Flange U Dimension
7	Gas Velocity Calibration Data Range
8	Specialty Gas Velocity Calibration
9	Safety Approvals
10	Process Pressure
11	Analog & Digital Inputs/Outputs
12	Process Temperature

FEATURE 1: ELECTRONICS ENCLOSURE CONFIGURATION AND INPUT POWER (See Note 1)	
Option	Description
A	Directly Attached Dual-Chamber Electronics Enclosure, AC-Power, LCD/Keypad.
B	Directly Attached Dual-Chamber Electronics Enclosure, AC-Power, without LCD/Keypad.
C	Directly Attached Dual-Chamber Electronics Enclosure rotated 180° for viewing, AC Power, LCD/Keypad.
D	Remote Dual-Chamber Electronics Enclosure, AC-Power, LCD/Keypad.
E	Remote Dual-Chamber Electronics Enclosure, AC-Power, without LCD/Keypad.
F	Directly Attached Dual-Chamber Electronics Enclosure, 24VDC-Power, LCD Keypad.
G	Directly Attached Dual-Chamber Electronics Enclosure rotated 180° for viewing, 24VDC-Power, LCD/Keypad.
H	Directly Attached Single-Chamber Electronics Enclosure, 24VDC-Power, without LCD/Keypad.
I	Remote Dual-Chamber Electronics Enclosure, 24 VDC-Power, LCD/Keypad.
J	Remote Single-Chamber Electronics Enclosure, 24 VDC-Power, without LCD/Keypad.

Note 1: The conduit or cable seal must be installed by an experienced and careful installer to prevent water intrusion into the enclosure and to maintain the enclosure rating. Failure to properly install the conduit seals may void the Kurz warranty and may compromise the safety approval rating.

Note 2: Stainless Steel Identification Tags are available. Customer must provide labeling information up to four lines of text with 32 characters each line.

SERIES 454FTB SINGLE-POINT INSERTION THERMAL MASS FLOW TRANSMITTERS

FIRST DIGIT OF FEATURE 2: SENSOR MATERIAL	
Option	Description
3	Alloy C-276
7	Alloy C-276 with Abrasion-Resistant Chromium Nitride Coating (CrN)

SECOND DIGIT OF FEATURE 2: SENSOR SUPPORT AND FLANGE MATERIAL (Note 1)	
Option	Description
2	316L Stainless Steel
3	Alloy C-276
8	Alloy C-276 with PTFE Teflon Coating cured for chemical resistance. Includes support, sensor and flange; FD2-HHT sensors only, temperature rating of 260°C Max.

Note 1: Sensor Support Material and Optional Flange Material must be the same, see Feature 5.

FEATURE 3: SENSOR SUPPORT LENGTH L			
Option	Support Length L	Option	Support Length L
B	6" (125°C Max)	J	30"
C	9" (260°C Max)	K	36"
D	12"	M	48"
F	18"	P	60"
H	24"		

FEATURE 4: PROCESS TEMPERATURE COMPENSATION	
<p>The influence of temperature on the thermal properties of gases requires temperature compensation of the Thermal Mass Flow Sensor for repeatability and accurate measurements. Standard Temperature Compensation (STC) is used for applications in which the process temperature is below 125°C over a moderate velocity range (Option 1); or below 260°C over more limited velocity range (Option 2).</p> <p>If the process temperature and gas velocity vary widely, Velocity/Temperature/Mapping (VTM) is recommended. VTM (Options 3, 4) includes several calibrations. The multiple velocity calibrations are entered into the Microprocessor which performs a double interpolation between the velocity calibration curves using the built-in process gas temperature measurement. The temperature compensation is based upon air, therefore, the accuracy at a high temperature when using gases other than Air, Nitrogen or Oxygen may be reduced unless a gas correlation is specified (see feature 8).</p>	
Option	Description
1	Standard Temperature Compensation (STC) over process Temperature range of -40°C to +125°C. Accuracy: ± (1% Reading + 20 SFPM) above or below 25°C (see note 1).
2	Standard Temperature Compensation (STC) over process Temperature range of 0°C to 260°C. Accuracy: ± (2% Reading + 20 SFPM) above or below 125°C (see note 1).
3	Velocity/Temperature/Mapping (VTM) with data sets over process temperature range of 0°C up to 260°C. Accuracy: ±(2% reading + 20 SFPM).
4	Velocity/Temperature/Mapping (VTM) with data sets over the process temperature range of 0°C up to 500°C. Accuracy: ±(3% reading + 30 SFPM), Specify Process Temperature Range. HHT Models.

Note 1: An accuracy specification of ± (0.025%/°C Reading + 0.25 SFPM/°C) should added for temperatures above or below standard.

FEATURE 5: OPTIONAL FLANGE CONNECTION SIZE AND RATING		
<p>How to Determine the U, L and L2 Dimensions for a Flange Connection</p> <p>When ordering a flange, you must specify the U dimension, and verify that the sensor support length L and L2 are appropriate for the Process Temperature. Kurz recommends that the centerline of the sensor be located at the center of the pipe or duct, and that experimental flow profile tests be made to obtain the velocity profile correction factor (VCF) and enter it into the 454FTB. Refer to the outline drawings in the Series 454FTB Brochure. Note: Flange material must match Sensor Support Material (Feature 2).</p> <p>U = The dimension between the centerline of the mass flow sensor and the flange mounting surface. The minimum U dimension is 4.0".</p> <p>L = The length of the sensor support tube (Feature 3).</p> <p>L2 = The length of sensor support between the flange mounting surface and the sensor support fitting. The minimum L2 is 5 inches for HT process temperatures and 8 inches for HHT process temperatures.</p> <p>L = U + L2 - 2.00"</p>		
Option	Sensor Support Diameter	Description
A	1/2", 3/4", 1"	No flange connection
B	1/2"	1/2", Class 150, ANSI B16.5
C	1/2"	1/2", Class 300, ANSI B16.5
D	1/2", 3/4"	3/4", Class 150, ANSI B16.5
E	1/2", 3/4"	3/4", Class 300, ANSI B16.5
F	1/2", 3/4", 1"	1", Class 150, ANSI B16.5
G	3/4", 1"	1", Class 300, ANSI B16.5
H	3/4", 1"	1 1/4", Class 150, ANSI B16.5
I	3/4", 1"	1 1/4", Class 300, ANSI B16.5
J	3/4", 1"	1 1/2", Class 150, ANSI B16.5
K	3/4", 1"	1 1/2", Class 300, ANSI B16.5
L	3/4", 1"	2", Class 150, ANSI B16.5
M	3/4", 1"	2", Class 300, ANSI B16.5
N	1"	2 1/2", Class 150, ANSI B16.5
P	1"	2 1/2", Class 300, ANSI B16.5
S	1"	3", Class 150, ANSI B16.5
T	1"	3", Class 300, ANSI B16.5
U	1"	4", Class 150, ANSI B16.5
V	1"	4", Class 300, ANSI B16.5

Note: Flange material must match the Sensor Support Material (Feature 2).

FEATURE 6: OPTIONAL FLANGE U DIMENSION	
Directions	
<p>Divide the U Dimension (inches) by 100, round off the resulting number to the right of the decimal point to three significant digits, enter the resulting three digit number without the decimal point. Enter 000 for no flange connection. U_{MIN} = 4"</p> <p>Example: The U Dimension is 7.74"; Enter 077.</p>	

FEATURE 7: GAS VELOCITY CALIBRATION DATA RANGE SFPM (NMPS) (Note 1)			
Option	Velocity	Option	Velocity
A	V _{MAX}	M	6,000 (28.0)
B	300 (1.4)	P	9,000 (41.9)
C	600 (2.8)	R	12,000 (56)
E	1,000 (4.7)	T	15,000 (70)
G	2,000 (9.3)	V	18,000 (84)
I	3,000 (14)	X	24,000 (112)
K	4,000 (18.6)		

Note 1: The Gas Velocity (V_p) must be equal to or less than than V_{MAX} for the Process Absolute Temperature and Pressure and for the specific Gas Category and Gas Type as determined using Tables 2 & 3 and Equations 1, 2.

SERIES 454FTB SINGLE-POINT INSERTION THERMAL MASS FLOW TRANSMITTERS

FEATURE 8: SPECIALTY GAS VELOCITY CALIBRATION

There are two Specialty Gas Velocity Calibration methods available:
 1. Laboratory Gas Velocity Calibration.
 2. Correlation Gas Velocity Calibration in which the Insertion Mass Flow Transmitter is calibrated in air and experimentally derived correlation factors are used to obtain calibration data for the specialty gas.

FEATURE 8: SPECIALTY GAS VELOCITY CALIBRATION (Note 1)

Laboratory Calibration Option	Gas Type Option	Correlation Calibration
01	Air	–
07	Compressed Air	–
–	Dry Ammonia	56
08	Argon	58
–	Butane	60
14	Carbon Dioxide	64
–	Dry Chlorine	68
20	Ethane	70
22	Ethylene	72
26	Helium	76
28	Hydrogen	78
32	Methane	82
35	"Digester Gas" 50% CH ₄ , 50% CO ₂	85
36	"Digester Gas" 60% CH ₄ , 40% CO ₂	86
37	"Digester Gas" 70% CH ₄ , 30% CO ₂	87
40	Nitrogen	90
44	Oxygen (Note 2)	94
46	Propane	96

Note 1: Laboratory Gas calibrations are performed with gases of high purity and are NIST Traceable. Customer must specify calibration pressure (Feature 10). Propane to 50 PSIA, all other gasses to 150 PSIA. Correlation calibrations are based on experimental data correlated to an air calibration at ambient pressure and temperature. The user's flow element is calibrated in air, and an additional calibration data sheet is made for the specialty gas based upon the correlation factors. Add ±5% of Reading to the accuracy specifications when using a gas correlation calibration. All correlations include VTM.

Note 2: It is the customer's responsibility to insure that the Mass Flow Element is clean of Hydrocarbons and is safe for oxygen use. (See Accessories in Section C-1 for Cleaning and Bagging).

FEATURE 9: SAFETY APPROVALS (Note 1)

Option	Description
A	Non-Incendive (NI), CSA, ATEX and IECEx Ex nA II, T6, T5, T4 or T150°C (electronics enclosure) Ex nA II, T5 or T3 (sensing element)
B	Explosion-Proof/Flame-Proof, CSA, ATEX and IECEx Ex d IIB + H2, T6, T4, T110°C or T150°C (electronics enclosure) Ex d IIB + H2, T4 or T3 (sensing element)

Note 1: See Specifications, Page 5.

FEATURE 10: PROCESS PRESSURE

Enter the Absolute Pressure (PSIA), rounded off to 3 digits. Example: For a Process Absolute Pressure of 14.7 PSIA, enter 015; for 150 PSIA, enter 150.

FEATURE 11: ANALOG AND DIGITAL INPUTS/COMMUNICATIONS

Option	Analog & Digital Inputs				Communication Protocols		
	No. of Alarm Relay Outputs (DO)	No. of 4–20mA Outputs (AO)	No. of Digital Inputs (DI)	No. of 4–20mA Inputs (AI)	USB	Modbus RS-485 RTU or ASC II	HART (FSK 7.0)
B ¹	0	2	0	0	Yes	Yes	No
C ²	2	2	2	1	Yes	Yes	No
E ³	2	1	2	1	Yes	Yes	Yes

¹Option B provides:

- Two 4-20 mA outputs for Flow Rate and/or Temperature, NAMUR NE-43 compliance.
- USB, Modbus and RS-485 communication protocols.

²Option C provides:

- Two 4-20 mA outputs for: Flow Rate, Temperature, EPA Zero-MidSpan-Span Drift check^{III} or PID Flow Control^{I,II}, NAMUR NE-43 compliance.
- Two alarm relays for: Flow Rate, Temperature or Pulsed Flow Totalizer. External 4-20 mA input.
- Two DI for EPA Zero-MidSpan-Span Drift Check or Purge Cycle Cleaning.
- USB, Modbus and RS-485 communication protocols.

³Option E provides:

- One 4-20 mA output for: Flow Rate, Temperature, EPA Zero-Mid-Span Drift check^{III} or PID Flow Control^{I,II}, NAMUR NE-43 compliance.
- Two alarm relays for: Flow Rate, Temperature or Pulsed Flow Totalizer. External 4-20 mA input.
- Two DI for EPA Zero-MidSpan-Span Drift Check or Purge Cycle Cleaning.
- HART Communication Interface, USB, Modbus and RS-485 communication protocols.

Notes:

- I. The PID Flow Controller uses one 4-20 mA output for the flow controller.
- II. The External Input PID Controller requires a 4-20 mA flow reference input.
- III. EPA Zero-MidSpan-Span Drift check normally requires a contact closure to verify that the Drift Check has been truly indicated. The contact closure is generated by the Continuous Emissions Monitor Computer at a specific time every day to indicate the Daily Drift Check. Both 4-20mA outputs are used during the Drift Check Calibration procedure.
- IV. The built in Purge Timer activates one of the Relays to open the customer's air solenoid (this is preset at the factory). The purge cycle is initiated by an external contact closure from the customer or by the built in timer or via Modbus. This leaves one relay available for other functions.

FEATURE 12: PROCESS TEMPERATURE

Enter the Absolute Process Temperature (°Rankin = °F + 460) rounded off to 4 digits. Example: For a Process Temperature of 77°F, enter 0537; for 932°F, enter 1392.

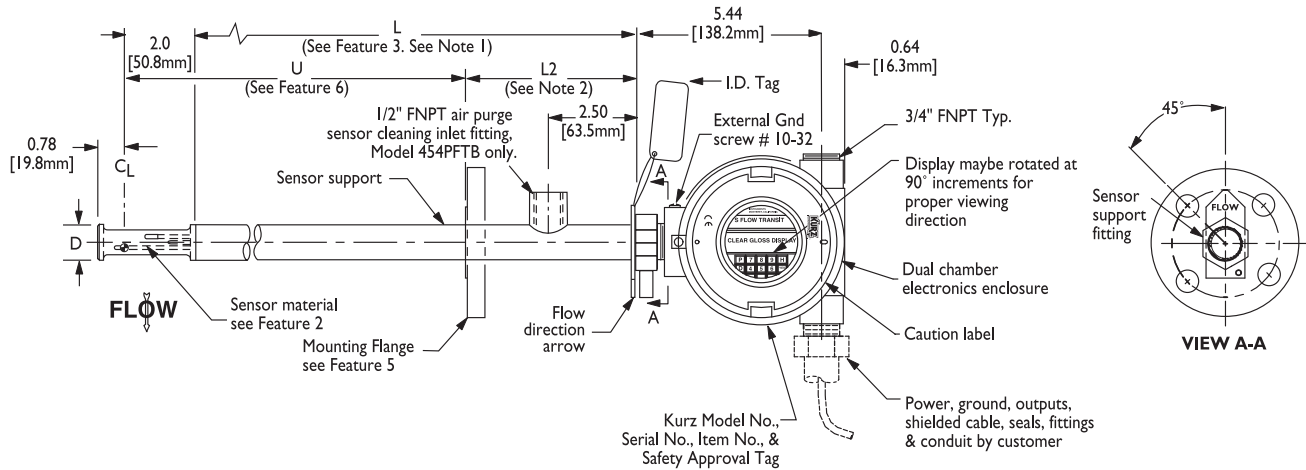

**Directly Attached Dual-Chamber Electronics Enclosure
Feature 1, Options A, F (Shown with Standard Display Orientation)**

Note 1: $L = U + L2 - 2.00"$, $U(\text{min}) = 4"$
Note 2: $L2(\text{min}) = 5"$ for HT Models and $8"$ for HHT Models

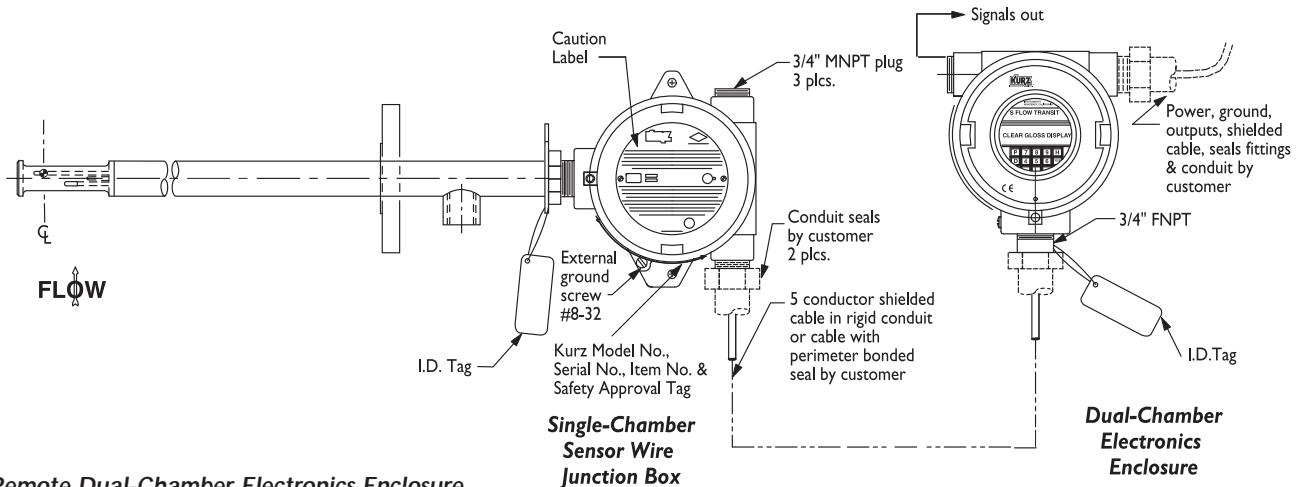

**Remote Dual-Chamber Electronics Enclosure
Feature 1, Options D, I**

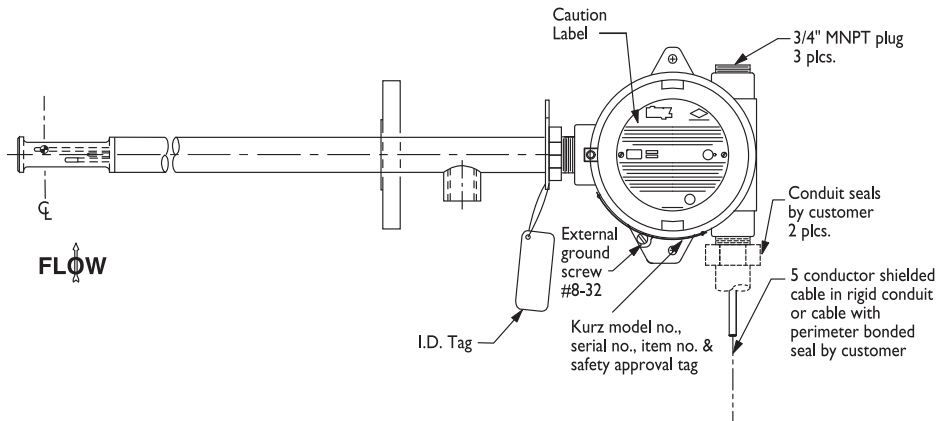

**Directly Attached Single-Chamber Electronics Enclosure
Feature 1, Option H**

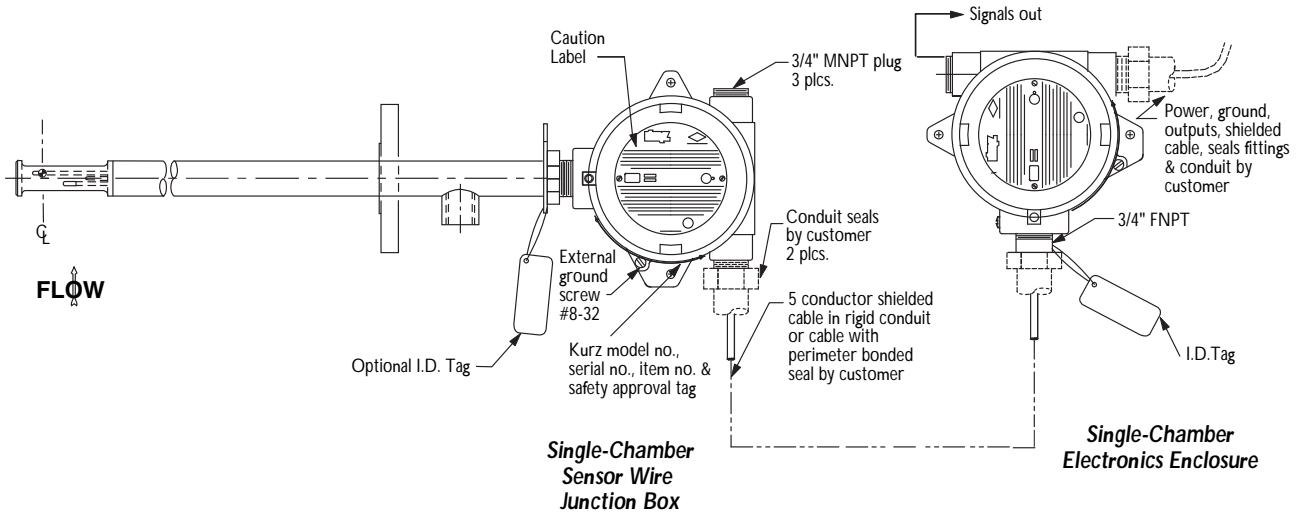

**Remote Single-Chamber Electronics Enclosure
Feature 1, Option J**

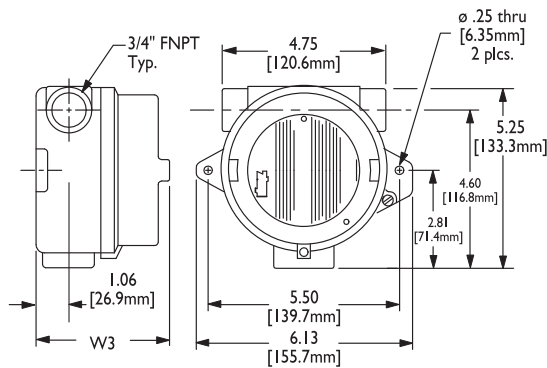

**Single-Chamber Sensor Wire Junction Box,
Single-Chamber Electronics Enclosure Dimensions**

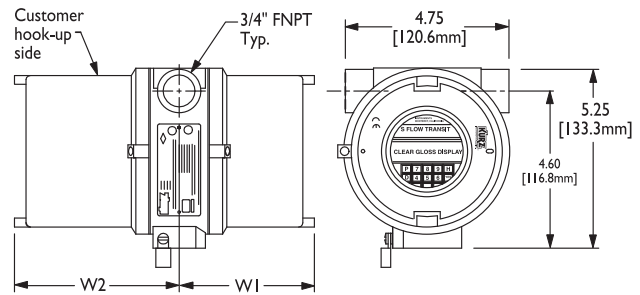

**Dual-Chamber Electronics Enclosure Dimensions
(Shown with Display)**

Enclosure Type	W ₃
Junction Box	3.88 [99mm]
Electronic Enclosure	5.94 [151mm]

Input Power	Display/Keypad	W ₁	W ₂
AC	Yes	3.41" (87mm)	4.69" [119mm]
AC	No	2.75" [70mm]	4.69" [119mm]
24 VDC	Yes	3.41" [87mm]	4.69" [119mm]



NSW

Sydney

13 Sirius Road, Lane Cove NSW 2066
Tel: +61 (0)2 9428 7377
Fax: +61 (0)2 9428 7379
Email: sydney@hmagroup.com.au

Wyong - Head Office

10 Hereford Street, Berkeley Vale NSW 2261
PO Box 5010 Chittaway NSW 2261
Tel: +61 (0)2 4389 6191
Fax: +61 (0)2 4389 6199
Email: info@hmagroup.com.au

QLD

Brisbane

4rd Floor, 49 Sherwood Road, Toowong QLD 4066
PO Box 106, Toowong QLD 4066
Tel: +61 (0)7 3859 6800
Fax: +61 (0)7 3859 6869
Email: brisbane@hmagroup.com.au

Mackay

22-30 Southgate Drive,
Southgate Industrial Park, Paget QLD 4740
PO Box 6221, Mackay Mail Centre QLD 4741
Tel: +61 (0)7 4998 6900
Fax: +61 (0)7 4998 6999
Email: mackay@hmagroup.com.au

Gladstone

9 Neil Street, Gladstone QLD 4680
PO Box 1731, Gladstone QLD 4680
Tel: +61 (0)7 4978 3128
Fax: +61 (0)7 4978 3127
Email: gladstone@hmagroup.com.au

Townsville

PO Box 347, Aitkenvale QLD 4814
Tel: +61 (0)7 4728 6300
Fax: +61 (0)7 4728 6388
Mobile: +61 (0)417 996 694
Email: townsville@hmagroup.com.au

WA

Perth

119 Dowd Street, Welshpool WA 6106
Tel: +61 (0)8 6254 9500
Fax: +61 (0)8 6254 9599
Email: perth@hmagroup.com.au

VIC

Melbourne

PO Box 204, Narre Warren VIC 3805
Mobile: +61 (0)429 176 688
Email: melbourne@hmagroup.com.au

Morwell

8 Jones Road, Morwell VIC 3840
PO Box 647, Morwell VIC 3840
Tel: + 61 (0)3 5136 8400
Fax: +61 (0)3 5136 8499
Email: morwell@hmagroup.com.au

SA

Adelaide

PO Box 1280, North Haven SA 5018
Tel: +61 (0)8 8341 8067
Fax: +61 (0)8 8341 8067
Mobile: +61 (0)437 460 032
Email: adelaide@hmagroup.com.au

NEW ZEALAND

Hamilton

Unit 14, 9 Karewa Place, Pukete, Hamilton NZ 3200
PO Box 10102, Te Rapa, Hamilton NZ 3241
Tel: +64 (0)7 847 1880
Fax: +64 (0)7 847 1883
Email: hamilton@hmagroup.co.nz

Wellington

Tel: +64 (0)7 847 1880
Fax: +64 (0)7 847 1883
Mobile: +64 272 612 744
Email: wellington@hmagroup.co.nz

Dunedin

Tel: +64 (0)27 511 6694
Fax: +64 (0)7 847 1883
Email: dunedin@hmagroup.co.nz

Halley & Mellowes Australasia Group of Companies