

SIKA Flow Switches



SIKA Flow Switches

Reliable – Safe – Proven !



Our tried-and-tested flow monitoring switches are used for two basic purposes:

- To ensure a minimum flow rate, e.g. of cooling water or lubricating oil (protects against running dry).
- To start a technical procedure when the flow begins.

Function

The flow monitoring switch comprises a paddle system (1) to whose end a permanent magnet is attached (2). Above this magnet is a reed contact (3), located outside the flow of fluid. A second magnet with opposing poles (4) creates the force necessary to reset the switch back to the no flow position.

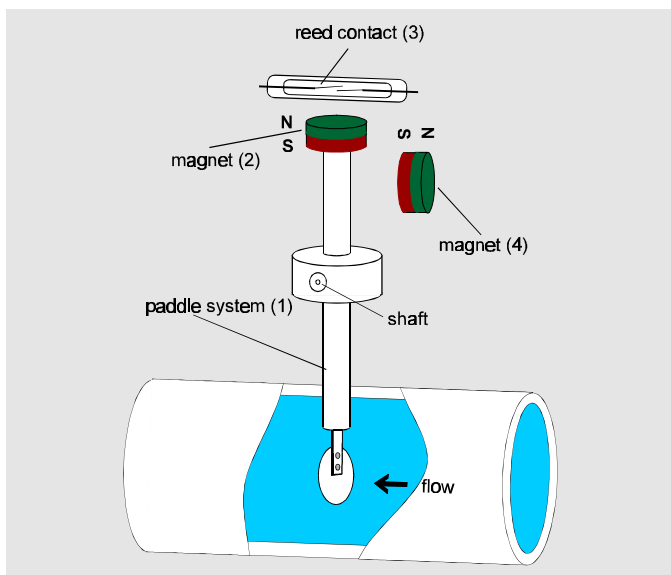

When the flow being monitored pushes against the paddle system, the paddle swings away. This changes the position of the magnet (2) in relation to the reed contact (3) and thus activates the contact.

As soon as the flow is interrupted, the paddle moves back to its starting position, thus activating the reed contact once again. The force necessary to push the magnet back is provided by the two magnets repelling each other.

Using magnetic force instead of the usual leaf spring means that the switch is considerably more stable in the long term and much less sensitive to pressure peaks.

Benefits that convince

- Adjustable switching point
- Low pressure drop
- Instant response
- High repeatability
- Can be used for liquids and gases
- Switching function dependent on flow rate alone, not on temperature or pressure

The reed contact used as a sensing element consists of two ferro-magnetic contact blades located in a glass bulb filled with inert gas. This practically eliminates wear resulting from contact burning. This construction allows a useful life of up to 100 000 000 switching cycles.

Factory settings are:

- contact closes when liquid is flowing
- contact opens if flow is interrupted

These settings can be changed by the customer if required.

You can also adjust the switch point setting within the specified range.

Options

- Specific set point adjustment, including special set points
- Optical flow indicator: LED in plug
- Teflon coating of wetted parts
- Reed contact for high switching performance
- Operating pressure up to 250 bar
- OEM design, proven in numerous series applications

Two different versions:

- Flow switch with pipe section (inline type) nominal diameter DN 8 to DN 50
- Flow switch insertion type for direct installation from above, directly into the pipeline nominal size DN 50 to DN 200

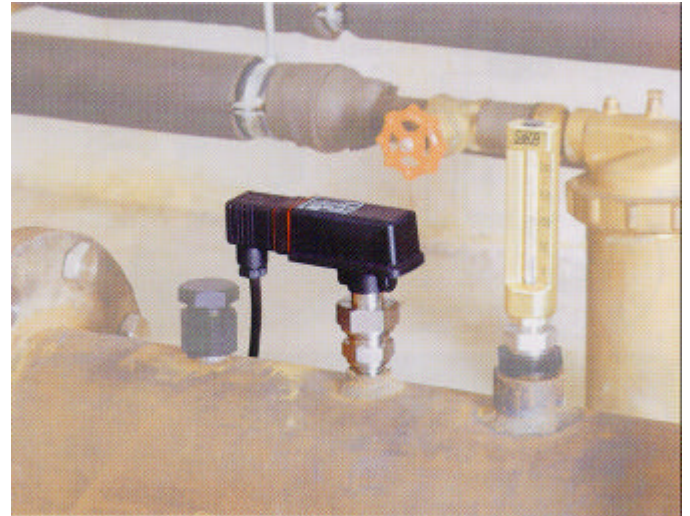

Available materials:

- Flow switch:
 - Brass
 - Stainless steel 1.4571
 - Plastic NORYL PPO GFN3
 - Brass with paddle system made of plastic
- Pipe section:
 - Brass
 - Stainless steel
 - Copper solder connection
 - PVC solvent bonded connection

Electrical connection-

- Standard:
 - Plug connector DIN 43650 form A / ISO 4400 incl. cable socket with terminal screws, suitable for cables with outer diameter 4.5 - 7 mm.
- Optional:
 - Plug connector DIN 43650 form A / ISO 4400 incl. plug with two LED for optical flow and power indication in plug (for switching voltages 24 V...230 V AC/DC).
 - 4-pin-sensor plug M12x1 acc. IEC 947-5-2, connection cables available as accessories, length 2 m and 5 m.

Technical data, series VHS/VKS...

Max. working pressure	VHS... VKS...	25 bar 10 bar
Max. medium temperature:	VHS... VKS... VKS...MKU	110°C 100°C 20°C (PN 10); 60°C (PN 2,5)
Ambient temperatur		80°C (VKS...MKU 60°C)
Protection class		IP 65
Max. switching current		1 A
Max. switching voltage		230 V AC, 48 V DC
Max. rating		26 VA, 20 W
Setpoint tolerance		± 15 %



Types for OEM applications upon request.

Flow Switch, Inline Type

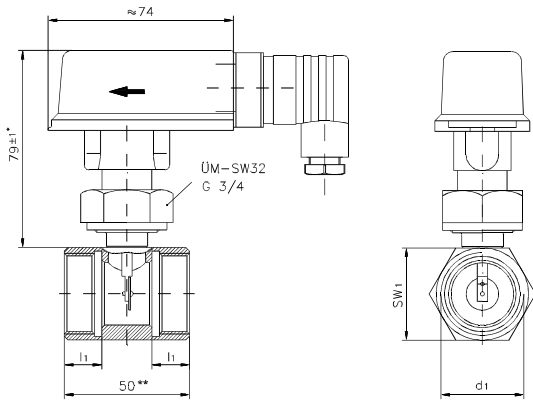

* stainless steel version: 82 ± 1
 ** 60 mm at VHS 15 MA:

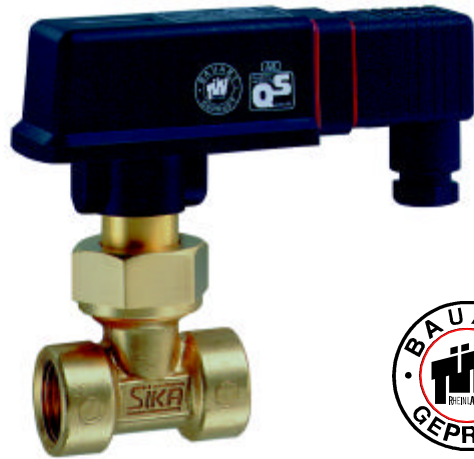

Type/ Order code	Size	Process connection d1	Setpoint ranges (H ₂ O, 20°C)		Max. flow rate [l/min]	Dimensions		
			increasing flow [l/min]	decreasing flow [l/min]		l ₁	Nut size sw ₁ [mm]	
							Brass	Stainless steel
VHS 08 M	DN 8	1/4" BSP	2,1...2,7	1,8...2,4	45	11	27	27
VHS 10 M	DN 10	3/8" BSP	2,5...3,2	2,2...2,9	60	11	19	27
VHS 15 M	DN 15	1/2" BSP	3,4...4,2	3,0...3,8	67	11	19	27
VHS 15 MA	DN 15	1/2" BSP male	2,5...3,2	2,2...2,9	60	10	19	—
VHS 20 M	DN 20	3/4" BSP	7,0...9,1	6,4...8,2	180	15	27	32
VHS 25 M	DN 25	1" BSP	13,5...17,0	12,0...15,5	195	15	32	41
VHS 32 M	DN 32	1 1/4" BSP	15,5...20,5	14,5...19,0	240	15	46	46
VHS 40 M	DN 40	1 1/2" BSP	26,5...34,5	25,5...32,5	400	15	55	55
VHS 50 M	DN 50	2" BSP	39,5...51,0	39,0...50,0	400	15	70	70

Materials and pressure drop diagram

Type	Material		
	Upper section	Paddle system	Pipe section
VHS .. M-MS	Brass	Brass	Brass*
VHS .. M-VA	Stainless steel	Stainless steel	Stainless steel
VHS .. MK	Brass	PPO Noryl GFN3	Brass*
VKS .. M	PPO Noryl GFN3	PPO Noryl GFN3	Brass*

* As an option, a copper tee piece, for soldered connections, can be supplied. This will alter the specified setpoint ranges.

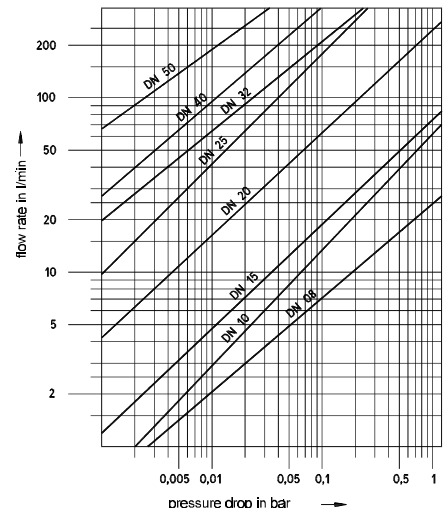

Flow Switch, Inline Type with PVC Pipe Section

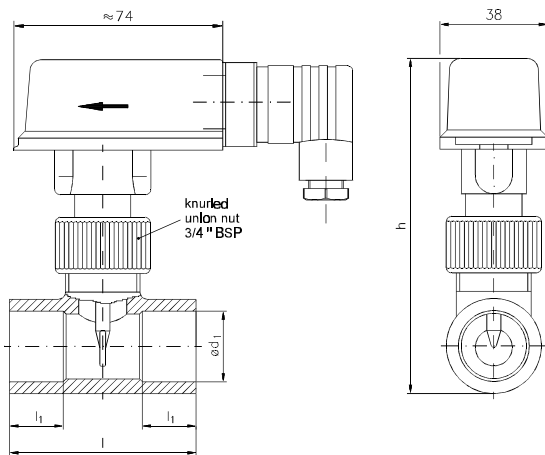

Type/ Order code	Size	Inside diameter d1	Setpoint ranges (H ₂ O, 20°C)		Max. flow rate [l/min]	Dimensions [mm]		
			increasing flow [l/min]	decreasing flow [l/min]		l ₁	l	h ≈
VKS 15 M KU	DN 15	20	5,1...6,9	4,9...6,5	50	16	54	113
VKS 20 M KU	DN 20	25	9,4...12,3	9,1...11,9	100	19	66	118
VKS 25 M KU	DN 25	32	10,7...15,2	10,4...14,8	100	22	78	127
VKS 32 M KU	DN 32	40	17,0...22,6	16,8...22,5	150	26	98	155
VKS 40 M KU	DN 40	50	21,8...30,1 (29,6...41,4)*	21,6...40,8 (29,4...40,8)*	200 (260)*	31	118	166
VKS 50 M KU	DN 50	63	29,0...40,0 (37,6...50,0)*	28,6...49,8 (37,4...49,8)*	260 (350)*	38	144	180

* The values in brackets are valid for shortened paddle

Materials

Upper section	Paddle system	Pipe section
PPO Noryl GFN3	PPO Noryl GFN3	PVC

Flow Switch, Insertion Type

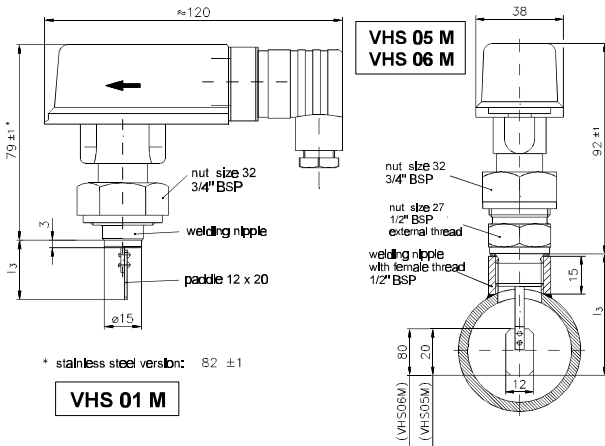

Type/ Order code	thread connection	Insert in size	Setpoint ranges (H ₂ O, 20°C)		Max. flow rate [m ³ /h]	Laid length l ₃ [mm]
			increasing flow [m ³ /h]	decreasing flow [m ³ /h]		
VHS 05 M	½" BSP	DN 50	1,9...2,7	1,8...2,6	30	51 ±1
		DN 80	5,0...8,0	4,9...7,9	80	
		DN 100	8,3...12,5	8,2...12,4	150	
		DN 150	17,5...25,0	17,4...24,9	200	
VHS 06 M	½" BSP	DN 100	5,7...6,3	5,6...6,2	100	111 ±1
		DN 150	11,0...13,0	10,9...12,9	150	
		DN 200	25,0...27,0	24,9...26,9	200	
VHS 01 M	Soldering/ welding nipple	DN 50	3,8...4,9	3,7...4,8	30	24 ±1
		DN 80	9,0...14,3	8,9...14,2	100	
		DN 100	13,0...18,8	12,7...18,4	150	
		DN 150	33,0...46,0	32,9...45,9	200	

Every flow switch type is suitable for integration in pipes of different sizes. For example the type VHS 05 M can be inserted into DN 50 to DN 150 pipes without modification but setpoint ranges will differ.

Materials

Type	Materials		Max. flow rate
	Upper section	Paddle system	
VHS .. M-MS	Brass	Brass	see above table
VHS .. M-VA	Stainless steel	Stainless steel	see above table
VHS .. MK*	Brass	PPO Noryl GFN3	upon request
VKS .. M*	PPO Noryl GFN3	PPO Noryl GFN3	upon request

* available with connection ½" BSP, not available with soldering/welding nipple.

Flow Switch with Micro Switch

A micro switch used as the sensing element allows a higher electrical switching capacity than the reed switch. The resetting force required by the paddle system is produced by a leaf spring.

The following versions are available:

- With pipe section, female thread, DN 10 to DN 50
- With pipe section, male thread, DN 15 only
- Insertion type for direct installation using soldering nipple on request

Standard material is brass.

Stainless steel version as an option.

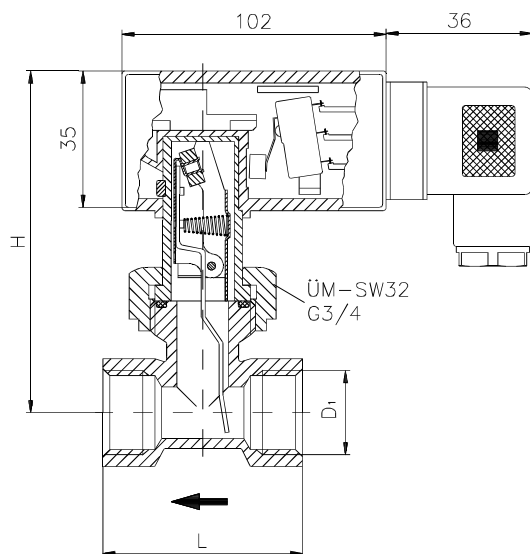

Technical data

Max. working pressure	25 bar
Max. medium temperature	100°C
Protection class	IP 65
Contact	Change-over contact
Max. switching current	5 A
Max. switching voltage	250 V AC
Max. rating	1250 VA
Setpoint tolerance	± 15 %
Setpoint hysteresis	as a function of the set point, min. 0,7 l/min
Max. pressure drop at max. flow	approx. 0,01 bar



Type/ Order code	Size	Process connection	Setpoint ranges (H ₂ O, 20°C) for decreasing flow [l/min]	max. flow rate H ₂ O [l/min]	Dimensions [mm]	
					L	H
VH 010 I	DN 10	3/8" BSP	4,0...5,0	10	50	85,5
VH 015 I	DN 15	1/2" BSP	5,0...6,0	20	50	85,5
VH 015 A	DN 15	1/2" BSP (male)	4,0...5,0	20	60	85,5
VH 020 I	DN 20	3/4" BSP	8,0...10,0	40	50	88,0
VH 025 I	DN 25	1" BSP	17,0...20,0	60	50	92,5
VH 032 I	DN 32	1 1/4" BSP	24,0...28,0	100	50	95,0
VH 040 I	DN 40	1 1/2" BSP	43,0...50,0	150	50	97,5
VH 050 I	DN 50	2" BSP	69,0...83,0	250	50	108,0