

Mini - Overtank - Level Indicators 1016-Mini

Mini - Overtank - Level Indicators 1016-Mini

Table of contents

Index

Table of contents	308
Description and function	309
Certificates / Approvals	310-311
Mini Overtank Level Indicators 1016-Mini	
Stainless steel to PN16	312
Stainless steel to PN16 with protection tube	313
Float without magnetic system	314
Spherical float in stainless steel	315-316
Cylindrical float in stainless steel	317
Cylindrical float in stainless steel and titanium	318
Cylindrical float in titanium	319
Magnetic roller indicator	320
Scale	321
Magnetic switch	322
Level sensor	323-324
Level sensor Magnetostrictive	325
Type key	326-328
Design process connections	329-331

Instructions for instrument selection in the catalogue

So that the customer gets the best equipment solution according to his requirements, we recommend this simple procedure using the following pages:

- Define the dimension of the fitting or interface (e.g. thread G2", DIN-flange DN25/PN16, etc.)
- Determine the electrical connection (e.g. terminal box, cable entry, plug, etc.)
- Find out the operating conditions, min. and max. operating pressure, temperature and specific gravity of the media at the max. operating temperature.
- With the size of the fitting and material of the instrument, a guide specification can be selected on pages 312 to 319.
- The full and final specification can now be generated by reference to the „type key“ on pages 326-328.
- With the type description and the technical operating conditions a price quotation can be made or the instrument can be ordered.
- Specification of the requested approval.

Mini - Overtank - Level Indicators 1016-Mini

Description and function

The mini overtank level indicator forms an integral part of a pressure vessel. A chamber is mounted on the top of a tank or container by means of a process connection. Inside the chamber of the mini overtank level indicator is a magnetic system, which is connected to a transmission rod. The concentrated magnetic field produced by the permanent magnet gives a precise reading for the level of liquid in the chamber. A signal is transmitted by the magnetic field through the wall of the chamber to an externally mounted indicator, as well as to recording and switchgear elements.

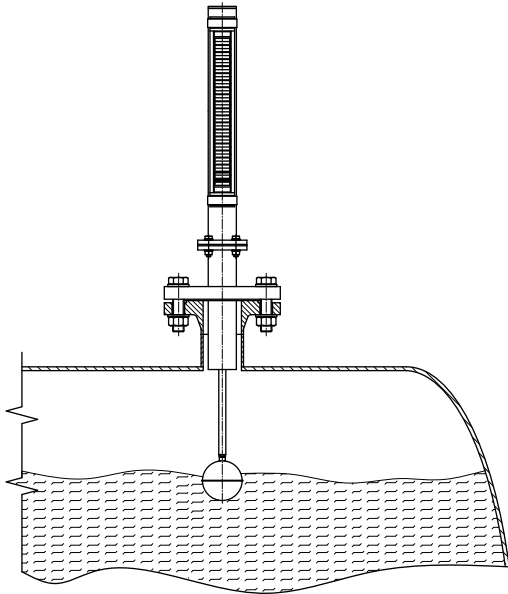

Magnetic Roller Indicators

are used for displaying the level visually. Small plastic or aluminium rollers with inlaid bar magnets are held in an aluminium or stainless steel profile bar. Depending on the level in the chamber, these rollers turn from white to red as the level rises and from red to white as the level falls. The level inside the vessel can thus be indicated continually without requiring any outside power source.

Level Sensors

are used for the electrical continuous remote indicator of levels. The magnetic field of the permanent magnet in the cylindrical float acts through the wall to activate very small reed contacts that continually register the measurement voltage on a resistance measurement chain. This measurement voltage is proportional to the level (3-wire potentiometer circuit). The resolution of the reed contacts is produced with spacings of 5, 10 and 15mm. When used in connection with a control unit, the resistance value can be converted into a standardized analogous signal.

Magnetic Switches

are used as limit value switches for various filling levels. The permanent magnet in the cylindrical float activates a potential-free bistable reed contact. Completely contactless, it sends out a binary signal that can be used as a „full/empty“, a „pump on/off“ or a „valve open/close“ signal. However, reed contacts are also ideally suited for forwarding signals directly to SPS control units.

Technical advantages

- Simple, robust and unbreakable design
- Pressure- and gas-proof separation between the measurement and the indicator chambers
- Detection and indication of the filling levels of aggressive, combustible, poisonous, hot, turbulent and severely contaminated media
- Guaranteed operation of the magnetic roller indicator without requiring an auxiliary power source, even in the case of power system failures
- Usable in all fields of industry tanks to the use of a wide range of corrosion-proof materials
- Designs available for pressure ranges from a vacuum up to 16 bar
- Designs available for temperature ranges from -40°C to +150°C
- Designs available for density as of 350 kg/m³

Mini - Overtank - Level Indicators 1016-Mini Certificates / Approvals

Certificates



SCHWEIZERISCHER VEREIN FÜR QUALITÄTS- UND MANAGEMENTSYSTEME

Certified according to ISO 9000 rev. 2000



SWISS TECHNICAL SERVICES AG

Approval as production factory, welding examination and procedure qualification incl. restamping certificate for the production of pressure tanks according to SVTI-regulation 501, 201

Approvals



TECHNISCHER ÜBERWACHUNGSVEREIN DEUTSCHLAND (PED)

Approval as production factory for manufacture of pressure tanks according to AD HP 0, PED Pressure Equipment Directive 97/23/EG



SOCIETE NATIONALE DE CERTIFICATION ET D'HOMOLOGATION (ATEX)

Approval for the production of mini-overtank-level indicators according to EU-Directive 94/9/EG

Mini - Overtank - Level Indicators 1016-Mini Approvals

As an innovative manufacturer of instruments for level control, we can offer to our customers systems according to different directives. The types of approval, applications and limits of use can be taken from the following specifications.

Approvals

Ex

A large number of mini-overtank-level indicators from our standard range, or to customer requests, can be built according to the ATEX-Directive 94/9/EG with the protection types EEx ia IIC T3 to T6, according to the corresponding electrical components in EEx d T4 to T6 or dust Ex/D. By the combination of the instruments with the type key the catalogue shows with the Ex hexagonal logo which components can be used for Ex-instruments.

Medium temperature:

EEx ia-instruments

T3	180 °C
T4	130 °C
T5	95 °C
T6	80 °C

EEx d-instruments

T4	120 °C
T5	95 °C
T6	80 °C

PED

Under the Pressure Equipment Directive 97/23/EG, any pressure vessel or instrument used within a pressurised system at 0,5 bar or above, has to conform to various categories. Depending on the design data or customer needs, manufacture of instruments is to either of the categories below.

Category II

Module	A1
--------	----

Category IV

Module	B+D
--------	-----

Mini - Overtank - Level Indicators 1016-Mini Stainless steel to PN16

Technical data

Material:	1.4301 / 304 1.4306 / 304L 1.4404 / 316 L 1.4435 / 316 L 1.4571 / 316 Ti
Chamber:	ø 40 x 2 mm
Chamber end top:	- Flat top
Process connections:	- Flange acc. to DIN - Flange acc. to Ansi - Tri-clamp flange - ...
Length of instrument:	L = 400 mm ... 5000 mm
Indicating range:	A = L - float length - (F)
Magnetic roller indicator:	- MNA - MNAV - MNKV - MNAN
Scale:	- ../SK / ../SG / ../VSG
Magnetic switch:	- See page 322
Level sensor:	- See pages 323-324
Insulation thickness:	- 30 mm - 60 mm
Approvals:	- See pages 310-311
Float:	- Acc. to table p. 314-319
Interface:	- Acc. to protocol

Operating parameters

Temperature:	-40 °C ... +150 °C
Pressure:	-1 ... 16 bar
Specific gravity:	≥ 400 kg/m ³
Accuracy:	5 mm
Repeatability:	+/- 2 mm

UNA - .. / .. - L .. - V .. - .. S ..
UMG - .. / .. - .. - .. K .. - L .. - V .. - .. S ..

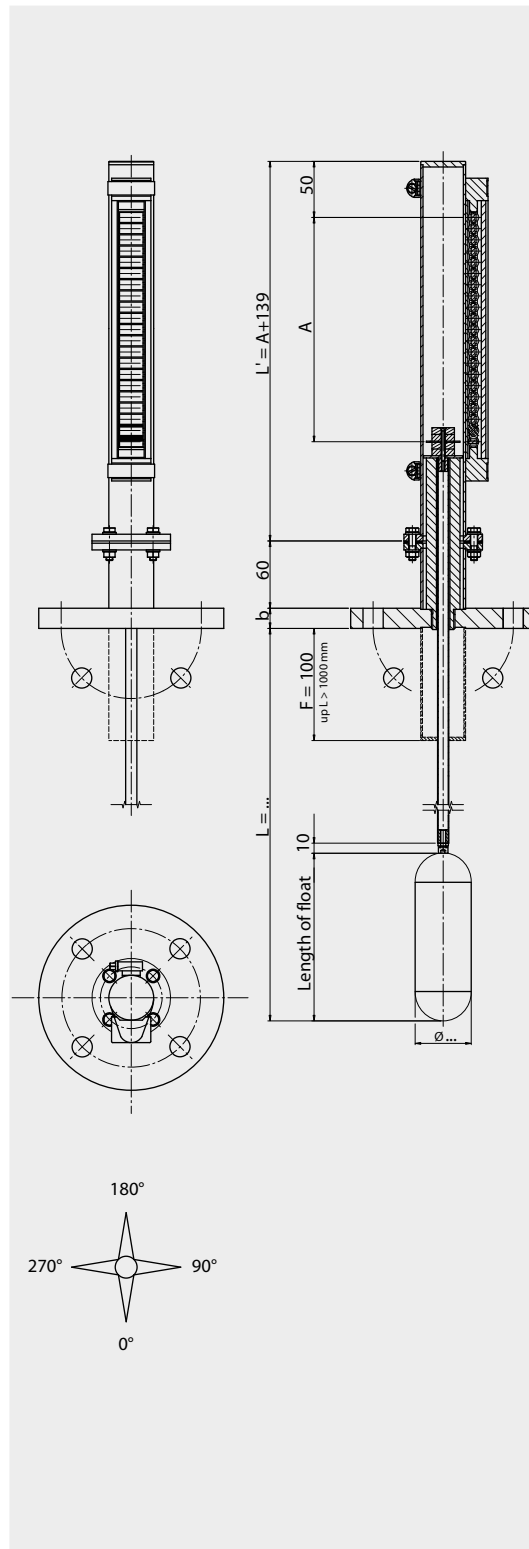

Type combination see type key Mini - Overtank - Level Indicators

Mini - Overtank - Level Indicators 1016-Mini Stainless steel to PN16 with protection tube

Technical data

Material:	1.4301 / 304 1.4306 / 304L 1.4404 / 316 L 1.4435 / 316 L 1.4571 / 316 Ti
Chamber:	ø 40 x 2 mm
Chamber end top:	- Flat top
Protection tube:	ø 60 mm ø 88 mm ø114 mm
Process connections:	- Flange acc. to DIN - Flange acc. to Ansi - Tri-clamp flange - ...
Length of instrument:	L = 400 mm ... 5000 mm
Indicating range:	A = L - float length
Magnetic roller indicator:	- MNA - MNAV - MNKV - MNAN
Scale:	- ../SK / ../SG / ../VSG
Magnetic switch:	- See page 322
Level sensor:	- See pages 323-324
Insulation thickness:	- 30 mm - 60 mm
Approvals:	- See pages 310-311
Float:	- Acc. to table p.314-319
Interface:	- Acc. to protocol

Operating parameters

Temperature:	-40 °C ... +150°C
Pressure:	-1 ... 16 bar
Specific gravity:	≥ 400 kg/m ³
Accuracy:	5 mm
Repeatability:	+/- 2 mm

UNA - .. / .. - L .. - V .. - .. S .. - SR ..
UMG - .. / .. - .. - .. K .. - L .. - V .. - .. S .. - SR ..

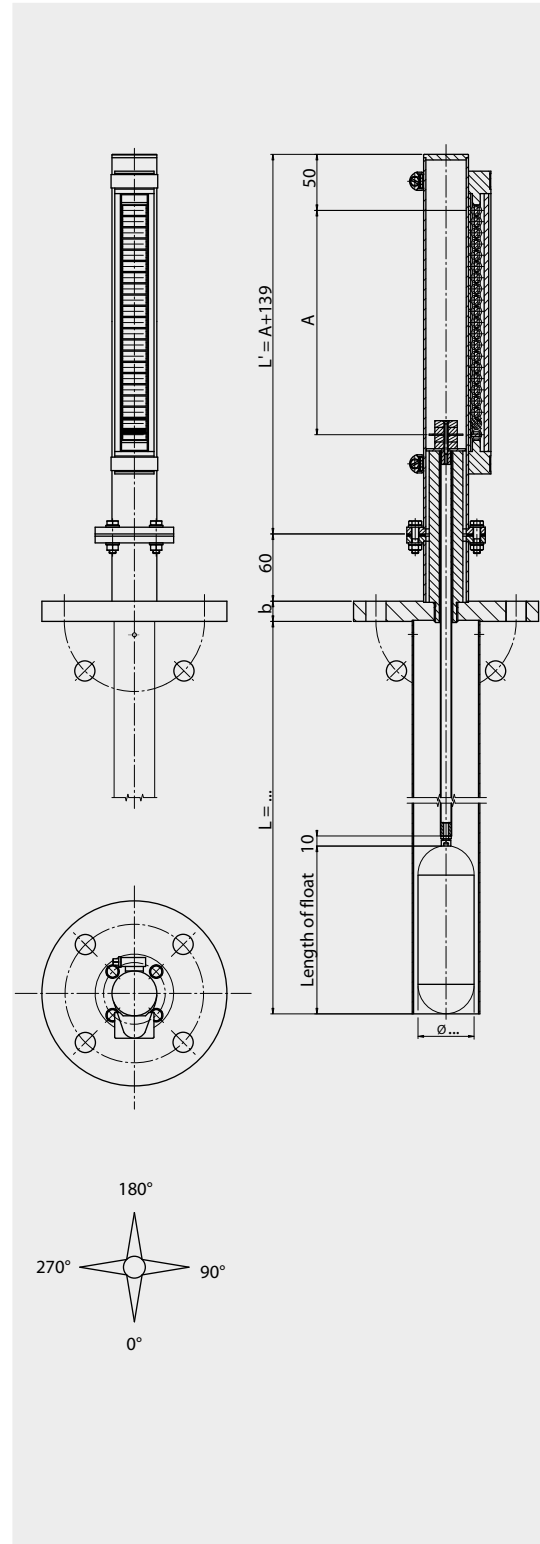

Type combination see type key Mini - Overtank - Level Indicators

Mini - Overtank - Level Indicators 1016-Mini Float without magnetic system

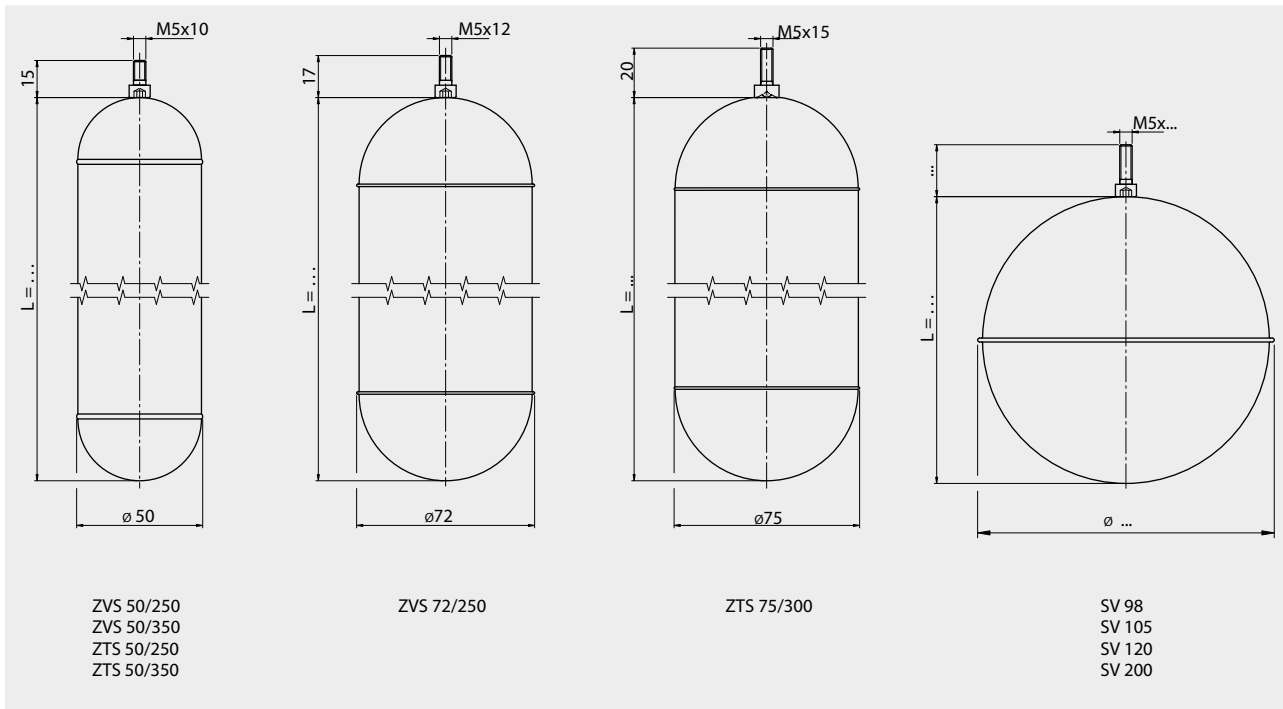

Cylindrical float

Type	Material	Cylinder ø [mm]	Length [mm]	Max. operating pressure [bar]	Max. operating temp. [°C]	Weight [g]	Min. flange	Plate thickness
ZVS50/250	St. steel	50	250	16	200	184	DN 50/PN16	0.6/0.5
ZVS50/350	St. steel	50	350	16	200	258	DN 50/PN16	0.6/0.5
ZVS72/250	St. steel	72	250	10	200	325	DN 80/PN16	0.8/0.6
ZTS50/250	Titanium	50	250	10	150	122	DN 50/PN10	0.71/0.7
ZTS50/350	Titanium	50	350	10	150	174	DN 50/PN10	0.71/0.7
ZTS75/300	Titanium	75	300	1	150	210	DN 100/PN10	0.71/0.7

Spherical float

Type	Material	Sphere ø [mm]	Length [mm]	Max. operating pressure [bar]	Max. operating temp [°C]	Weight[g]	Min. flange	Plate thickness
SV98	St. steel	98/95	95	16	200	180	DN100/PN16	0.8
SV105	St. steel	105/102	102	25	200	257	DN100/PN25	1.0
SV120	St. steel	120/116	116	16	200	235	DN125/PN16	0.7
SV200	St. steel	205/200	200	6	200	788	DN200/PN10	0.8

Specifications subject to change

Mini - Overtank - Level Indicators 1016-Mini

Spherical float in Stainless steel

Spherical float type SV 98

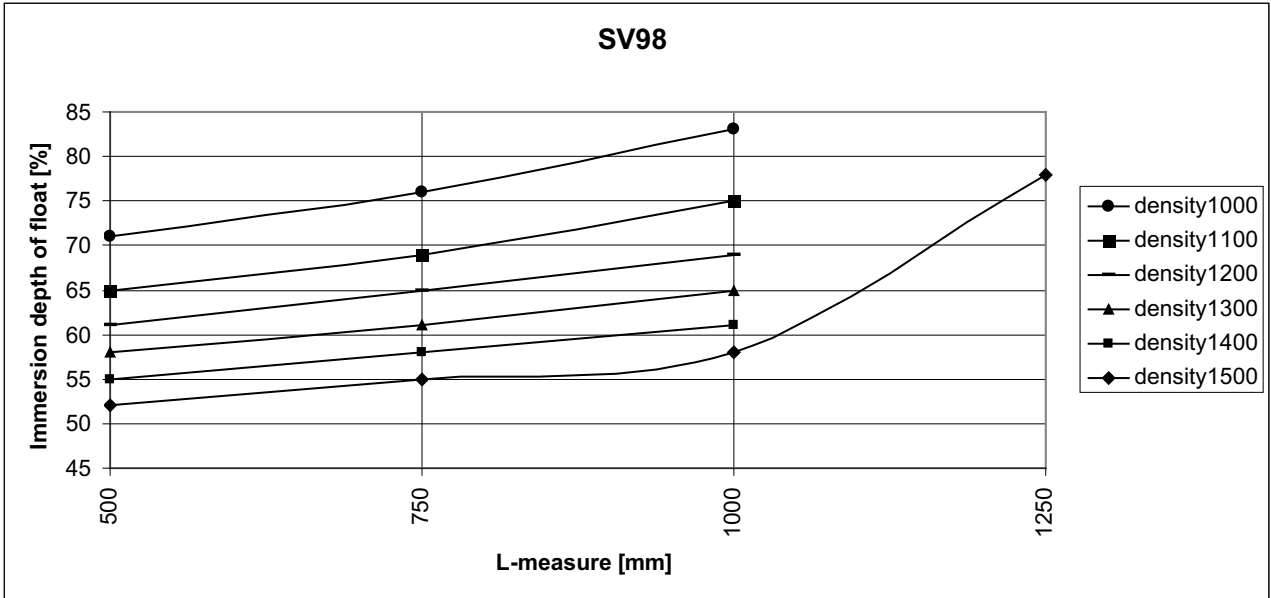

Spherical float type SV 105

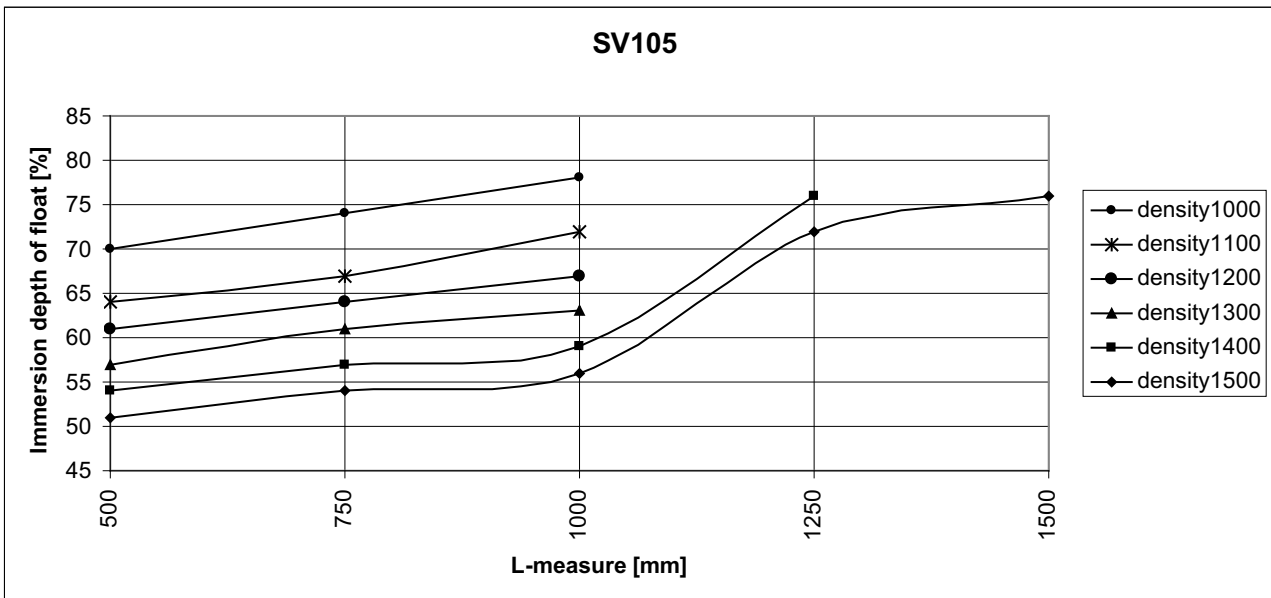

Mini - Overtank - Level Indicators 1016-Mini

Spherical float in Stainless steel

Spherical float type SV 120

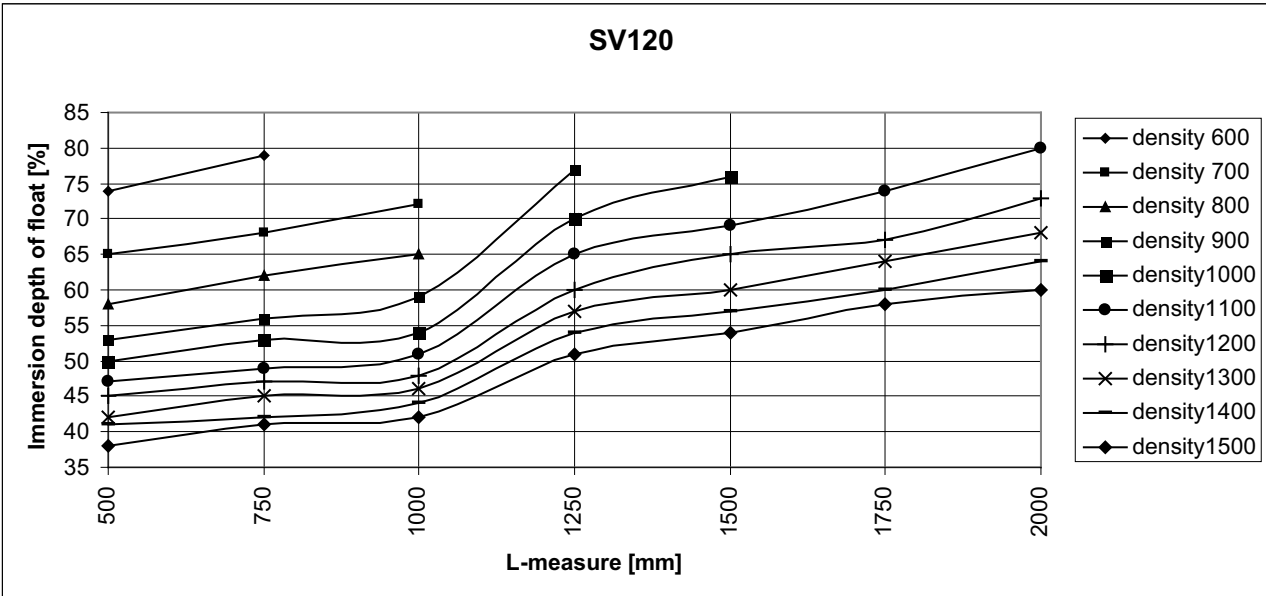

Spherical float type SV 200

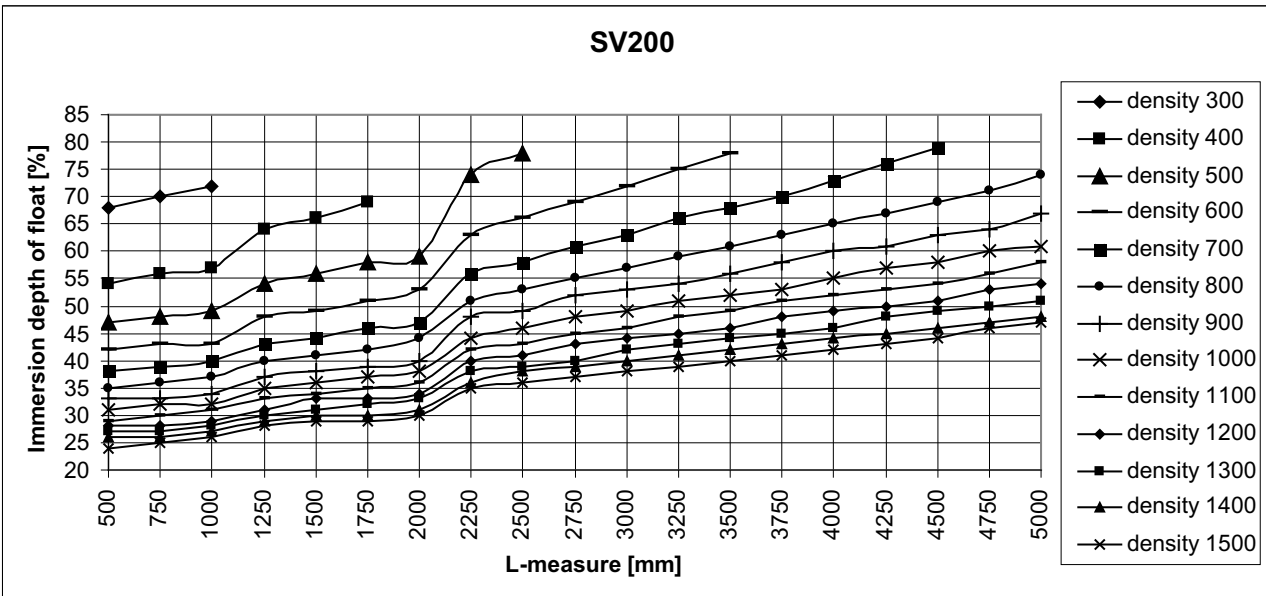

Mini - Overtank - Level Indicators 1016-Mini Cylindrical float in Stainless steel

Cylindrical float type ZVS 50/250

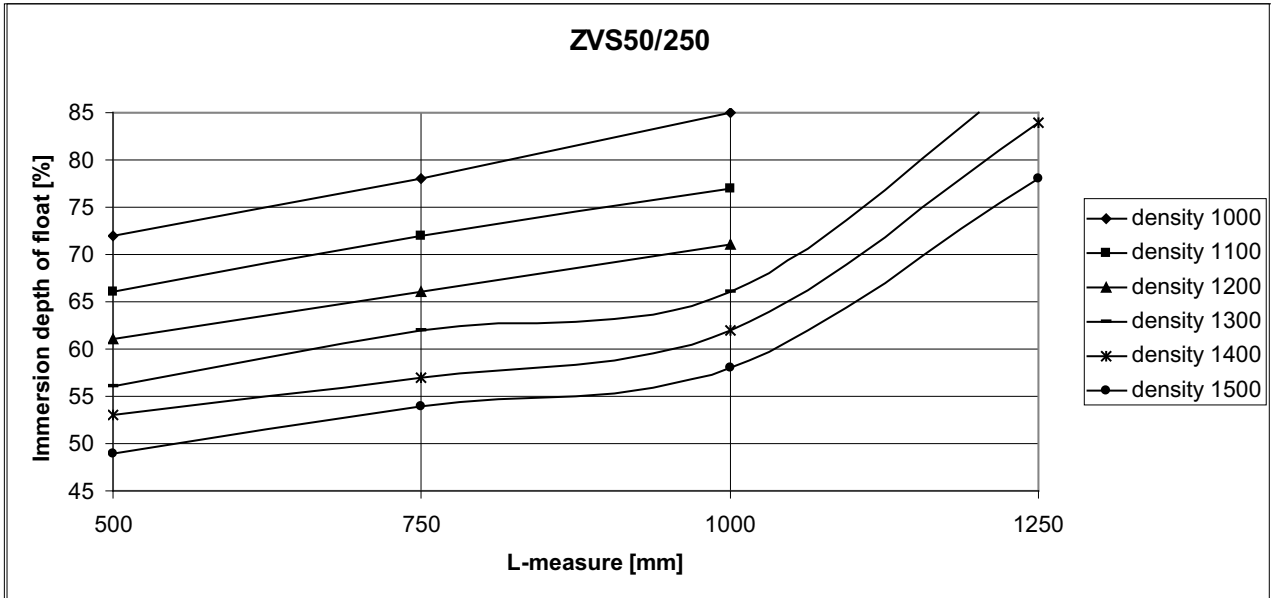

Cylindrical float type ZVS 50/350

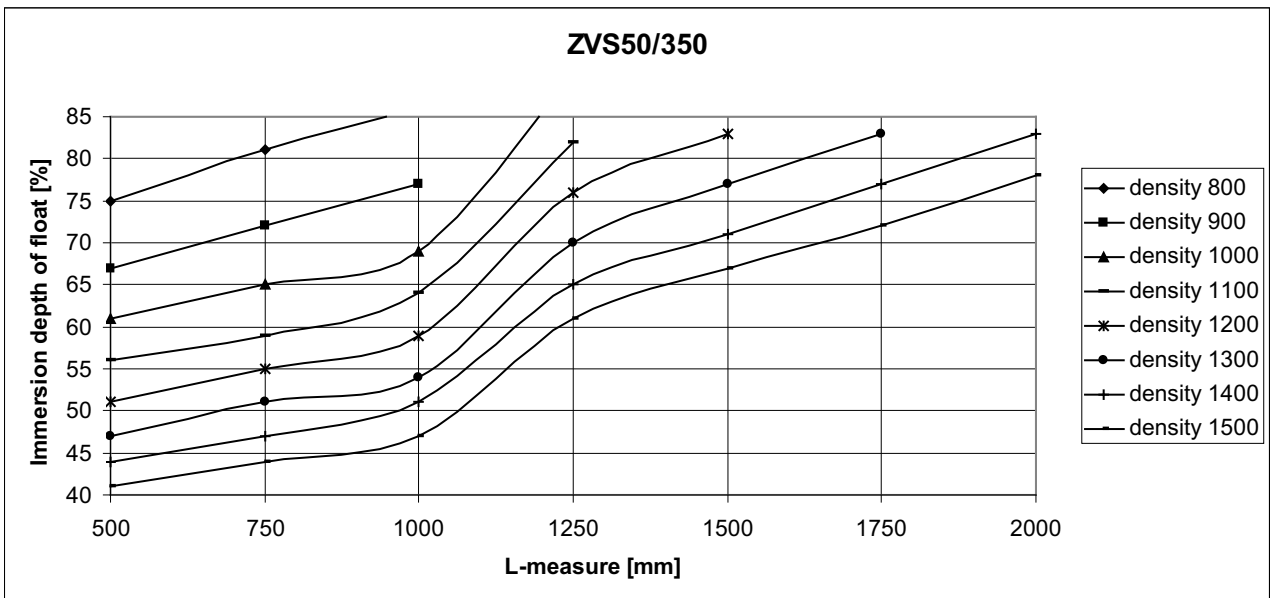

Mini - Overtank - Level Indicators 1016-Mini Cylindrical float in Stainless steel and Titanium

Cylindrical float type ZVS 72/250

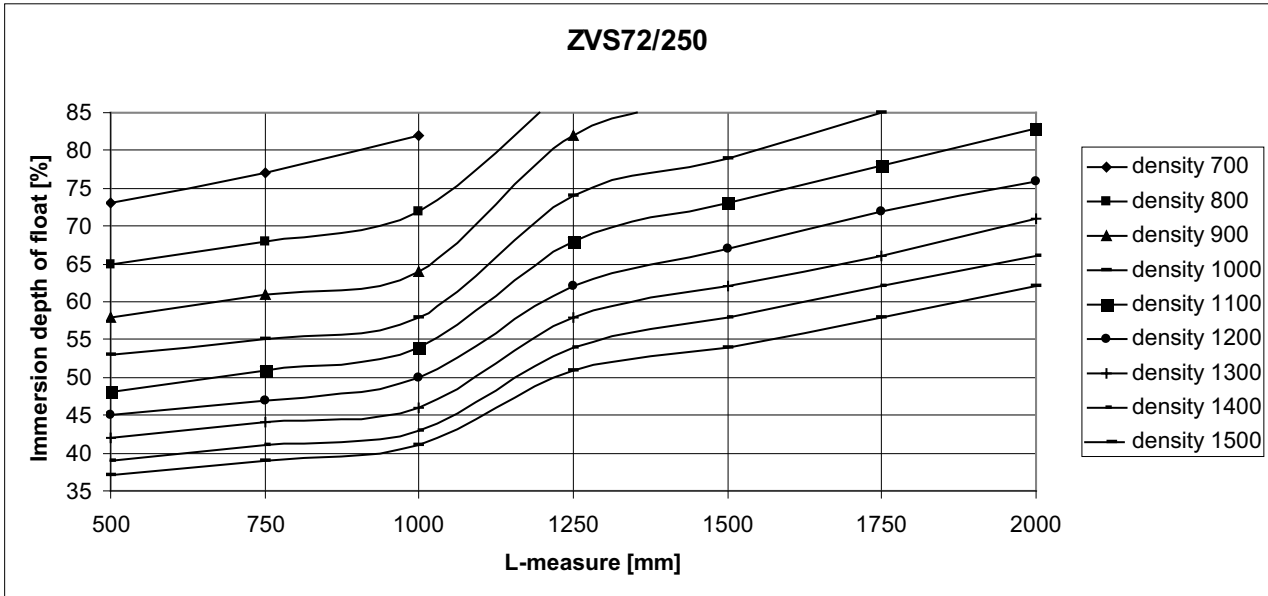

Cylindrical float type ZTS 50/250

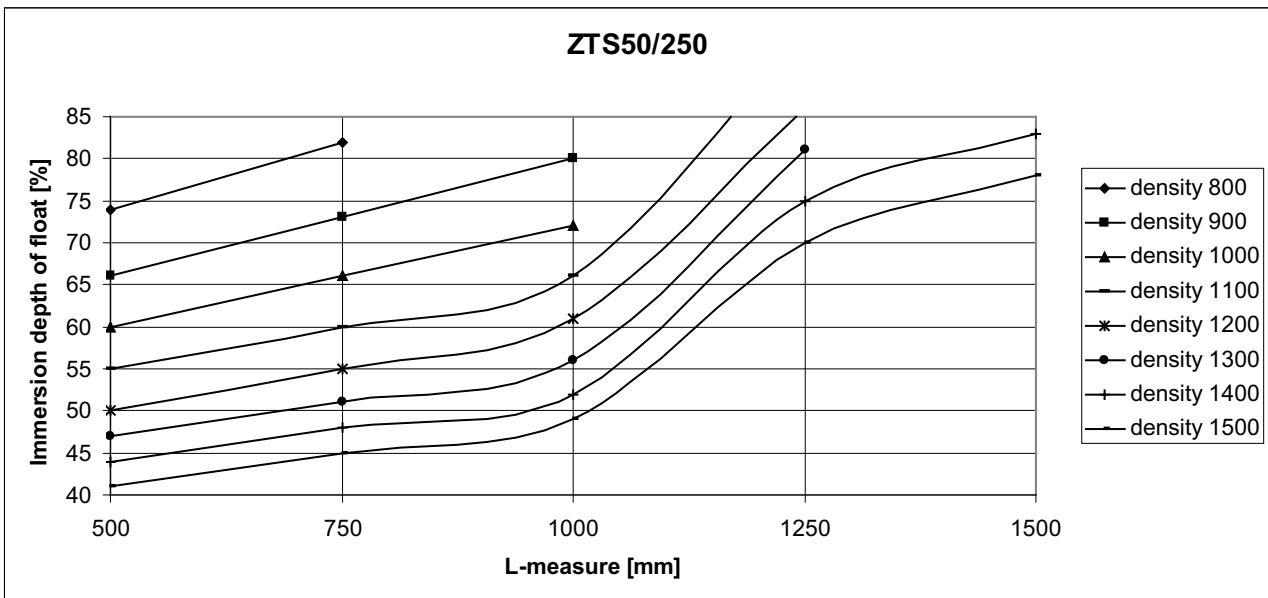

Mini - Overtank - Level Indicators 1016-Mini Cylindrical float in Titanium

Cylindrical float type ZTS 50/350

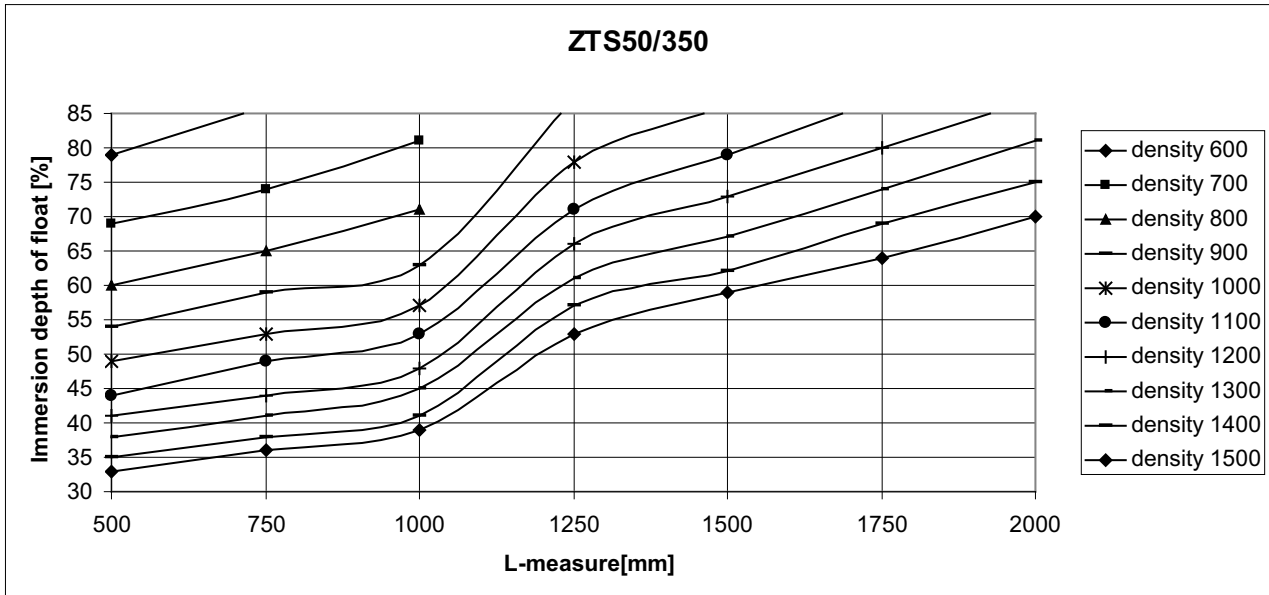

Cylindrical float type ZTS 75/300

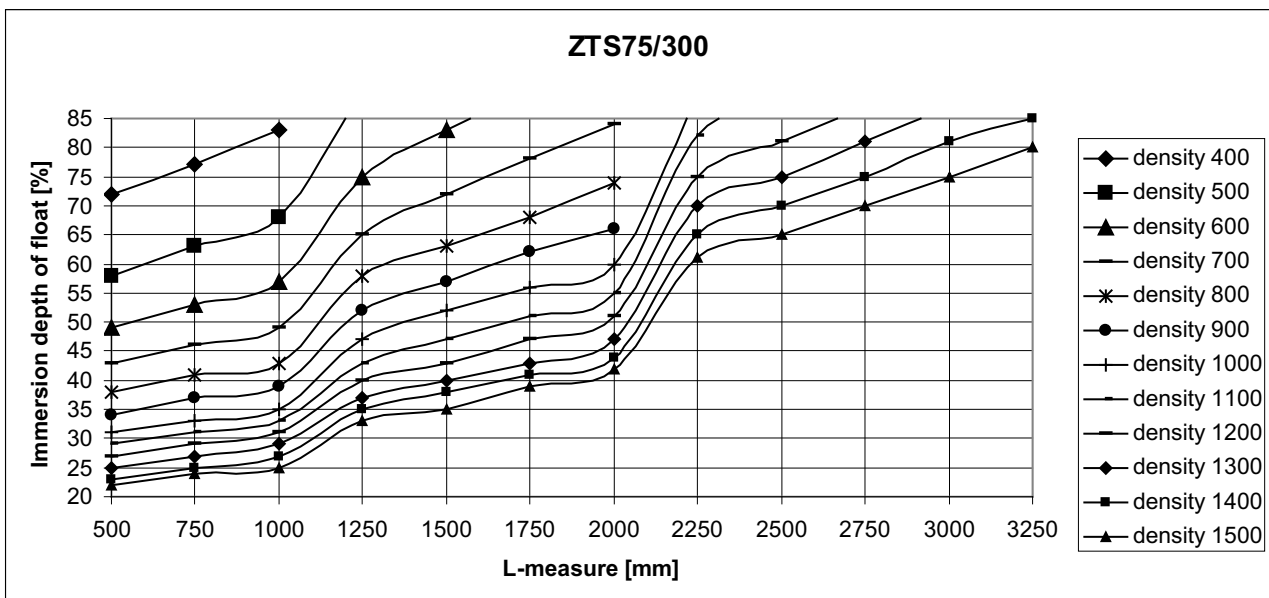

Mini - Overtank - Level Indicators 1016-Mini Magnetic roller indicator

Magnetic roller indicator MNA - M ..

Housing:
- aluminium anodized

Indicator rolls MNA:
- material: pocan
- colours: white / red

Cover:
- macrolon (standard)
- glass

Ambient temperature:
- MNA -40 °C ... +150 °C

Protection rating:
- IP 64 (optional IP 67)

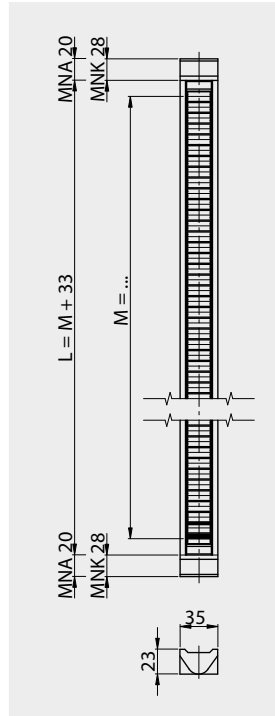

Magnetic roller indicator MNAV - M ..

Housing:
- stainless steel

Indicator rolls MNAV:
- material: pocan
- colours: white / red

Cover:
- macrolon (standard)
- glass

Ambient temperature:
- MNAV -40 °C ... +150 °C

Protection rating:
- IP 64 (optional IP 67)

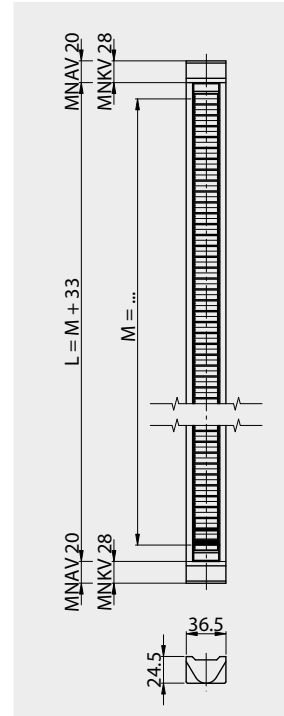

Magnetic roller indicator MNAN - M ..

Housing:
- aluminium anodized

Indicator rolls MNAN:
- material: pocan
- colours: white / red

Shock proof design:
- rollers turning max. 180°

Cover:
- macrolon (standard)
- glass

Ambient temperature:
- MNAN -40 °C ... +150 °C

Protection rating:
- IP 64 (optional IP 67)

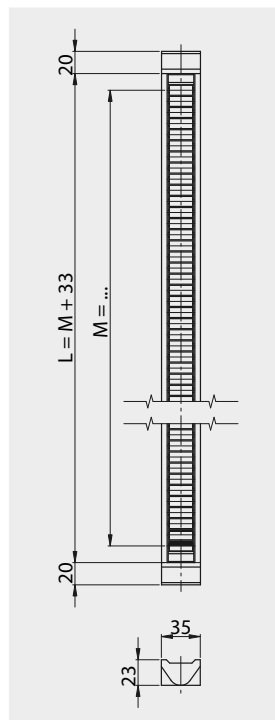

Type combination see type key Mini - Overtank - Level Indicators

Mini - Overtank - Level Indicators 1016-Mini Scale

**Scale
.. / SK**

Angle profile:
- aluminium

Width:
- 40 mm

Scale:
- adhesive foil

Separation:
- in cm

Ambient temperature:
- max. +80 °C

**Scale
.. / SG**

Angle profile:
- aluminium

Width:
- 40 mm

Scale:
- engraved

Separation:
- acc. to specification

Ambient temperature:
- max. +150 °C

**Scale
.. / VSG**

Angle profile:
- Stainless steel

Width:
- 40 mm

Scale:
- engraved

Separation:
- acc. to specification

Ambient temperature:
- max. +150 °C

Type combination see type key Mini - Overtank - Level Indicators

Mini - Overtank - Level Indicators 1016-Mini Magnetic switch

Technical data

Housing:

- anodised aluminium

Contact function:

- change over

Switching action:

- bistable

Switching capacity:

- 230 V AC or DC / 30 VA / 0.5 A

Protection rating:

- IP65

Ambient temperature:

- with PVC-cable max. +80 °C

Options:

- with code addition .. / R
with 22 Ohm protection resistor
- with code addition .. / N (acc.to Namur EN 60947)

RUM - AL - .. PVC

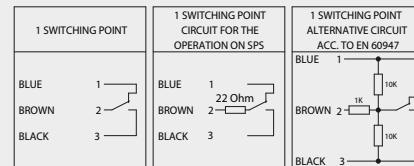
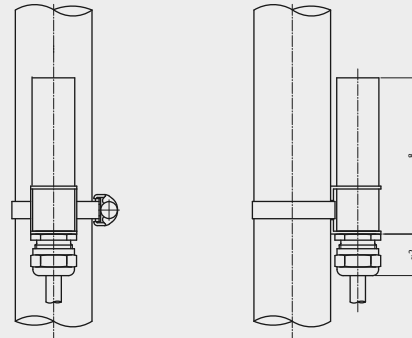

Technical data

Housing:

- anodised aluminium

Contact function:

- change over

Switching action:

- bistable

Switching capacity:

- 230 V AC or DC / 30 VA / 0.5A

Protection rating:

- IP65

Ambient temperature:

- with Silicone-cable max. +150 °C

Options:

- with code addition .. / R
with 22 Ohm protection resistor
- with code addition .. / N (acc.to Namur EN 60947)

RUM - AL - .. Sil

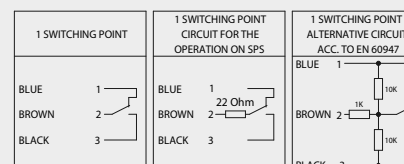
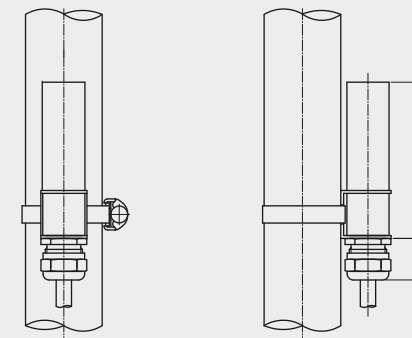

Type combination see type key Mini - Overtank - Level Indicators

Mini - Overtank - Level Indicators 1016-Mini Level sensor

Technical data	
Terminal box:	Aluminium
	A 105: 80 x 75 x 57
	A 101: 64 x 58 x 34
Dimensions:	
	A 105 A 101
	A = 85.5 mm A = 62.5 mm
	B = 75.0 mm B = 50.0 mm
	C = 89.0 mm C = 68.0 mm
Measuring chain tube:	ø 14 mm
Resolution:	
	5.0 mm -30 °C ... +130 °C
	10.0 mm -30 °C ... +130 °C
	15.0 mm -30 °C ... +130 °C
	5.0 mm (HTF) -30 °C ... +150 °C
	10.0 mm (HTF) -30 °C ... +150 °C
	15.0 mm (HTF) -30 °C ... +150 °C
Control unit:	TP5343A/B TP5350A/B TD5335A/B XT-42-SI

AL - .. - VK .. - M

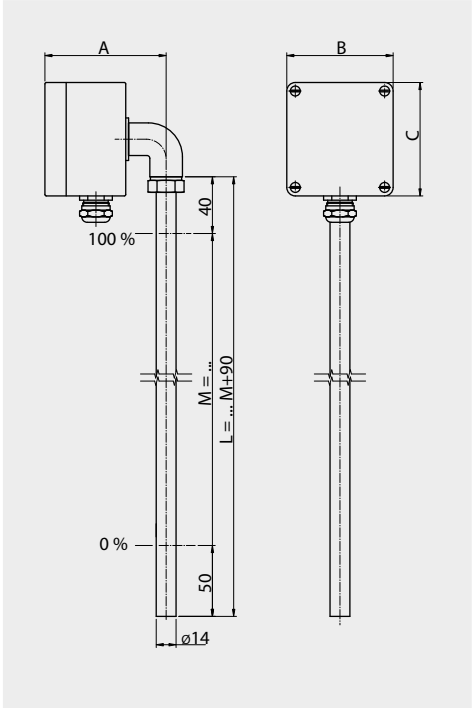

Technical data	
Terminal box:	Stainless steel
	92 x 82 x 95 mm
Cable gland:	Brass nickel-plated
Dimensions:	
	A = ~145 mm
	B = ~ 82 mm
	C = ~ 92 mm
Measuring chain tube:	ø 14 mm
Resolution:	
	5.0 mm -30 °C ... +130 °C
	10.0 mm -30 °C ... +130 °C
	15.0 mm -30 °C ... +130 °C
	5.0 mm (HTF) -30 °C ... +150 °C
	10.0 mm (HTF) -30 °C ... +150 °C
	15.0 mm (HTF) -30 °C ... +150 °C
Control unit:	TP5343A/B TP5350A/B TD5335A/B XT-42-SI
Option:	Cable gland in stainless steel

AV - .. - VK .. - M ..

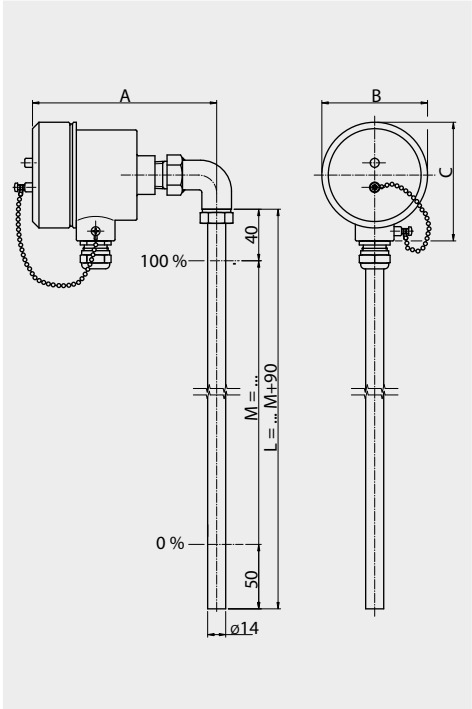

Type combination see type key Mini - Overtank - Level Indicators

Mini - Overtank - Level Indicators 1016-Mini Level sensor

Technical data	
Terminal box:	Aluminium 102 x 87 x 85 mm
Dimensions:	A = ~125 mm B = ~ 87 mm C = ~102 mm
Measuring chain tube:	ø 14 mm
Resolution:	5.0 mm -30 °C ... +120 °C 10.0 mm -30 °C ... +120 °C 15.0 mm -30 °C ... +120 °C
Control unit:	TP5343A/B TP5350A/B TD5335A/B XT-42-SI
Ambient temperature EExd:	+85 °C

ALDC - .. - VK .. - M .. - EExd

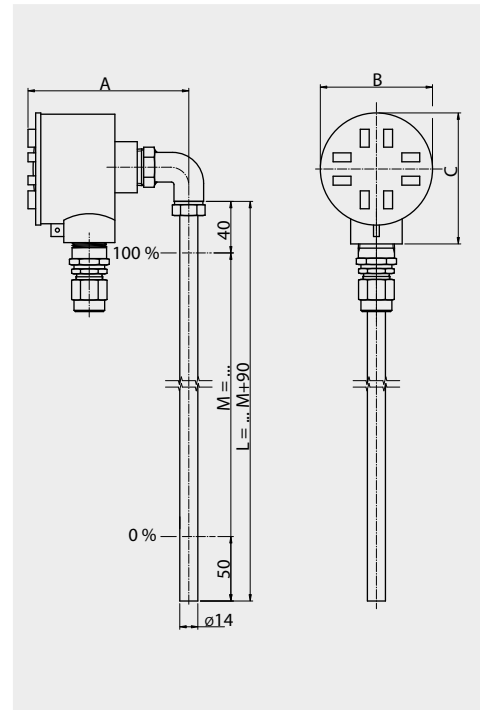

Technical data	
Terminal box:	Stainless steel 92 x 82 x 95 mm
Cable gland:	Brass nickel-plated (standard)
Dimensions:	A = ~145 mm B = ~ 82 mm C = ~ 92 mm
Measuring chain tube:	ø 14 mm
Resolution:	5.0 mm -30 °C ... +120 °C 10.0 mm -30 °C ... +120 °C 15.0 mm -30 °C ... +120 °C
Control unit:	TP5343A/B TP5350A/B TD5335A/B XT-42-SI
Option:	Cable gland in stainless steel
Ambient temperature EExd:	+40 °C

AVD - .. - VK .. - M .. - EExd

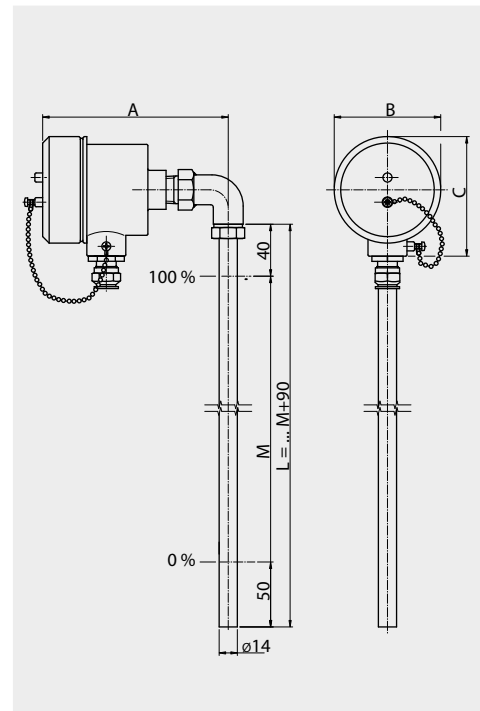

Type combination see type key Mini - Overtank - Level Indicators

Mini - Overtank - Level Indicators 1016-Mini

Level sensor Magnetostrictive

Technical data

Terminal box:	Ø 52 x 112 mm
Dimensions:	A= 52 mm B= 52 mm C= 112 mm
Screwed cable gland:	M16 x 1.5 mm
Length of instrument:	200 ... 6000 mm
Resolution:	0.1 mm -40 °C ... +125 °C 0.1 mm -200 °C ... +150 °C
Electrical connections:	2-wire connection (Option HART®)
Electrical power supply:	10 ... 30 V DC / 4 ... 20 mA
Ambient temperature:	-40 °C ... +85 °C
Measuring range:	free adjustable
System of protection:	IP68
Material:	Stainless steel

AMU - M ...

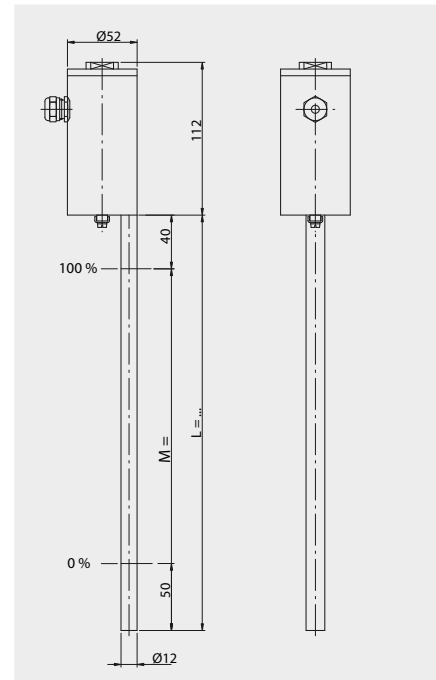

Technical data

Terminal box:	Ø 52 x 112 mm
Dimensions:	A= 52 mm B= 52 mm C= 112 mm
Screwed cable gland:	M16 x 1.5 mm
Length of instrument:	200 ... 6000 mm
Resolution:	Hazardous area 0 + 1 0.1 mm -20 °C ... +60 °C Hazardous area 2 0.1 mm -20 °C ... +60 °C 0.1 mm (HT) -20 °C ... +150 °C
Electrical connections:	2-wire connection (Option HART®)
Electrical power supply:	10 ... 30 V DC / 4 ... 20 mA
Ambient temperature:	-20 °C ... +85 °C
Measuring range:	free adjustable
System of protection:	IP68
Material:	Stainless steel
Approvals:	TÜV Atex 1772 X, II ½ G EExia T2 - T6

AMU - M ... - Ex

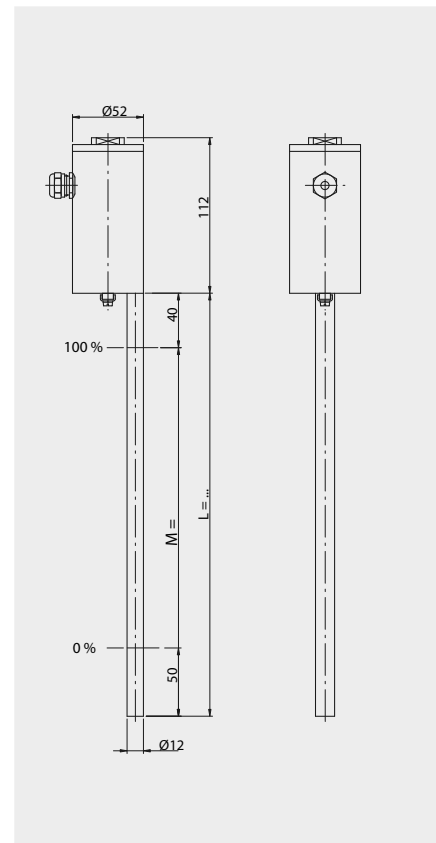

Type combination see type key Mini - Overtank - Level Indicators

Mini - Overtank - Level Indicators 1016-Mini

Type key

Code 1	Key 1		ATEX
	UNA -	Overtank - Level Indicators	
	UMG -	Overtank - Level Indicators with level sensor	
Code 2	Key 1	Design process connections	ATEX
	.. / .. / .. -	Flange norm 1. nom. width 2. nom. pressure 3. form	
		DIN DN 6 .. 500 PN 6 .. 400 C, F, N, B ..	
		ANSI 1/2" .. 24" 150 lbs .. 2500 SF, RTJ, RF..	
		JIS B 2010 2" .. 20" 5K .. 63K A .. T	
		BSI BS 4504 DN 10 .. 500 PN 2.5 .. 400	
		S Special flange with outside diameter mm	
	G .. -	GM thread female .."	
		GN thread male .."	
	NPT .. -	NPTM thread female .."	
		NPTN thread male .."	
	SE .. -	Welding ends .."	
	OS -	Without lateral connections	
Code 3	Key 1	Electrical connection for level sensor	ATEX
	AL -	Aluminium terminal box	
	AV -	Stainless steel terminal box	
	ALDC -	Aluminium terminal box EExd explosion proof	
	ALD -	Aluminium terminal box EExd explosion proof	
	AVD -	Stainless steel terminal box EExd explosion proof	
	AP -	Terminal box polyester	
	AB -	Terminal box ABS	
	E -	Connection cable	
	U .. -	Connection mountend on bottom (with appropriate electrical connection)	
	.. -	Various	

Type combination

Code	1	2	3	4	5	6	7	8	9	10
Key	1	1	1/2/3	1	1	1/2	1/2	1	1	1
Example	UMG -	50/16/C -	AL-VK5 -	L500-	V40 -	MNA -	-	ZTS250 -	-	Ex

Mini - Overtank - Level Indicators 1016-Mini

Type key

Code 3	Key 2	Control unit in terminal box	ATEX
	ZMU -	XT-42-SI	
	ZMUP -	956045	
	ZMUL -	2251	
	TP -	TP 5333B	
	TPA -	TP 5333A	
	TP43 -	TP 5343B	
	TP43A -	TP 5343A	
	TP50 -	TP 5350B	
	TP50A -	TP 5350A	
	TD -	TD 5335B	
	TDA -	TD 5335A	
	AMU -	AMU	
	.. -	Various	
	Key 3	Design resolution in stainless steel tube	ATEX
	VK5 -	Resolution 5.00 mm	
	VK5 (HTF) -	Resolution 5.00 mm high temperature	
	VK10 -	Resolution 10.00 mm	
	VK10 (HTF) -	Resolution 10.00 mm high temperature	
	VK15 -	Resolution 15.00 mm	
	VK15 (HTF) -	Resolution 15.00 mm high temperature	
	.. -	Various	
Code 4	Key 1	Length of instrument in mm	ATEX
	- L .. -	Length of instrument in mm	
Code 5	Key 1	Material of the chamber and diameter	ATEX
	.. V40 -	Stainless steel 1.4404 / 1.4435 / 1.4571	
	.. B40 -	Stainless steel 1.4301 / 1.4306 (standard)	
	.. -	Various	
Code 6	Key 1	Design with magnetic roller indicator	ATEX
	MNA / .. -	Aluminium profile with plastic rollers	
	MNAN / .. -	Aluminium profile with plastic rollers shock proof	
	MNAV / .. -	Stainless steel profile with plastic rollers	

Type combination

Code	1	2	3	4	5	6	7	8	9	10
Key	1	1	1/2/3	1	1	1/2	1/2	1	1	1
Example	UMG -	50/16/C-	AL-VK5 -	L500 -	V40 -	MNA -	-	ZTS250 -	-	Ex

Mini - Overtank - Level Indicators 1016-Mini

Type key

Code 6	Key 2	Scale for mounting onto magnetic roller indicator	ATEX
	.. / SK -	Aluminium scale with adhesive foil, separation in cm	
	.. / SG -	Aluminium engraved, separation acc.to specification	
	.. / VSG -	Stainless steel engraved, separation acc.to specification	
Code 7	Key 1	Quantity of magnetic switches	ATEX
	.. / RUM - AL -	Aluminium housing	
	Key 2	Cable connection with legh in m	ATEX
	.. PVC -	.. Polyvinylchloride PVC (PVC-grey)	
	.. PVC-blau -	.. Polyvinylchloride PVC (PVC-blue)	
	.. Sil -	.. Silicone	
	.. PUR -	.. Pur (partly oil resisting)	
	.. FEP -	.. Teflon	
	.. Lit -	.. Insulated stranded wire	
	.. NiLit -	.. Insulated nickel stranded wire with glass insulation	
	.. Radox -	.. Radox	
	.. -	.. Various	
	Options		
	.. / CY	Shielded cable	
	.. / ÖL	Oil resisting cable	
Code 8	Key 1	Float and float diameter / length in mm	ATEX
	ZVS .. -	Stainless steel cylindrical	
	SV .. -	Stainless steel spherical	
	ZTS .. -	Titanium cylindrical	
	.. -	Various	
Code 9	Key 1	Protection tube designs	ATEX
	- SR60 -	Diameter 60 mm	
	- SR88 -	Diameter 88 mm	
	- SR114 -	Diameter 114 mm	
Code 10	Key 1	Approvals and options	ATEX
	Ex	Intrinsically safe design acc.to EExia	
	EExd	Explosion proof design acc.to EExd	
	Ex/D	Intrinsically safe design acc.to EExia	
	EExd/D	Explosion proof design acc.to EExd	

Type combination

Code	1	2	3	4	5	6	7	8	9	10
Key	1	1	1/2/3	1	1	1/2	1/2	1	1	1
Example	UMG -	50/16/C -	AL-VK5 -	L500-	V40 -	MNA -	-	ZTS250 -	-	Ex

Mini - Overtank - Level Indicators 1016-Mini

Design process connections

Thread G ..."

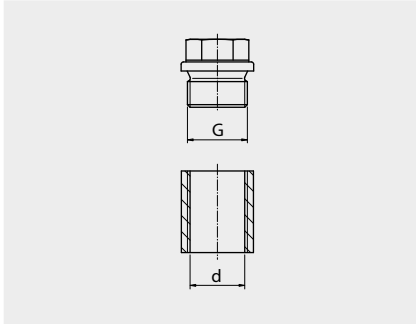

Size	Diameter G [mm]	Core ø d [mm]	Bore [mm]
1/8"	9.7	8.5	8.0
1/4"	13.2	11.4	11.0
3/8"	16.7	14.9	14.5
1/2"	21.0	18.9	18.0
3/4"	26.5	24.1	23.5
1"	33.3	30.2	29.5
1 1/2"	47.8	44.9	44.0
2"	59.7	56.6	56.0

Thread R ..."

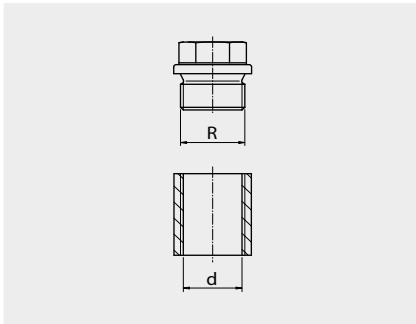

Size	Diameter R [mm]	Core ø d [mm]	Bore [mm]
1/8"	9.7	8.5	8.0
1/4"	13.2	11.4	11.0
3/8"	16.7	14.9	14.5
1/2"	21.0	18.6	18.0
3/4"	26.5	24.1	23.5
1"	33.3	30.2	29.5
1 1/2"	47.8	44.8	44.0
2"	59.7	56.6	56.0

Thread NPT ..."

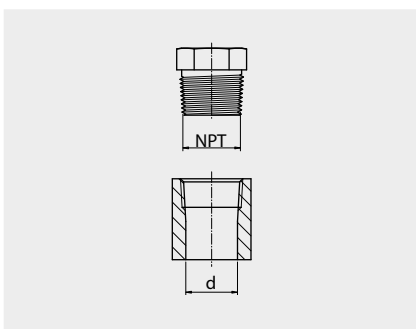

Size	Diameter NPT [mm]	Core ø d [mm]	Bore [mm]
1/8"	9.6	8.4	8.5
1/4"	12.8	11.2	11.0
3/8"	16.2	14.6	14.5
1/2"	19.9	18.2	18.0
3/4"	25.6	23.4	23.0
1"	31.8	29.8	29.0
1 1/2"	46.8	44.2	44.0
2"	58.6	56.4	56.0

Flange Tri - Clamp DIN 32676

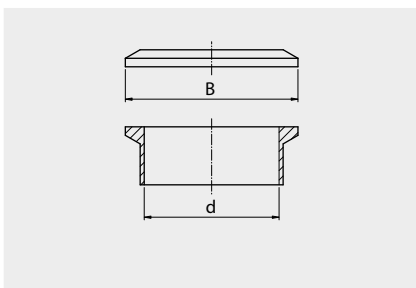

Size	Diameter B [mm]	Inside ø d [mm]	Bore [mm]
DN15	34.0	16.0	15.0
DN20	34.0	20.0	19.0
DN25	50.5	26.0	25.0
DN50	64.0	50.0	48.0
DN65	91.0	66.0	64.0
DN80	106.0	81.0	79.0
DN100	119.0	100.0	98.0

Mini - Overtank - Level Indicators 1016-Mini

Design process connections

Tube connection DIN 11851

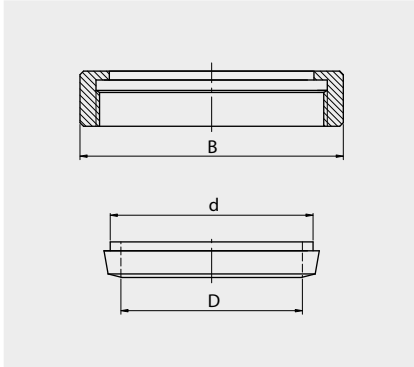

Size	Bore \varnothing d [mm]	Inside \varnothing D [mm]	Union nut B [mm]
DN10	18	10	38
DN15	24	16	44
DN20	30	20	54
DN25	35	26	63
DN40	48	38	78
DN50	61	50	92
DN65	79	66	112
DN80	93	81	127
DN100	114	100	148

Flange DIN 16 bar DIN 2633

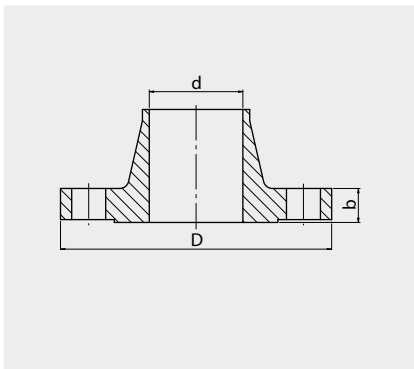

Size	Flange \varnothing D [mm]	Inside \varnothing d [mm]	Flange thickness b [mm]
DN10	90	13.6	14
DN15	95	17.3	14
DN20	105	22.3	16
DN25	115	28.5	16
DN40	150	43.1	16
DN50	165	54.5	18
DN65	185	70.3	18
DN80	200	82.5	20
DN100	220	107.1	20

Flange Ansi 150 lbs B 16.5

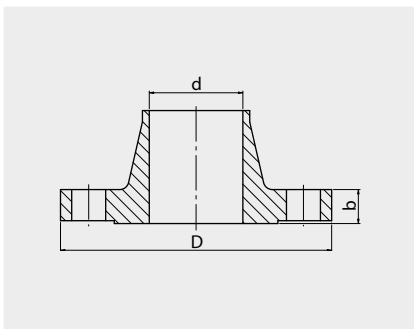

Size	Flange \varnothing D [mm]	Inside \varnothing d [mm]	Flange thickness b [mm]
1/2"	88.9	15.7	11.2
3/4"	98.6	20.8	12.7
1"	108.0	26.7	14.2
1 1/2"	127.0	40.9	17.5
2"	152.4	52.6	19.1
2 1/2"	177.8	62.7	22.4
3"	190.5	78.0	23.9
4"	228.6	102.4	23.9

Mini - Overtank - Level Indicators 1016-Mini

Design process connections

Flange DIN 40 bar DIN 2635

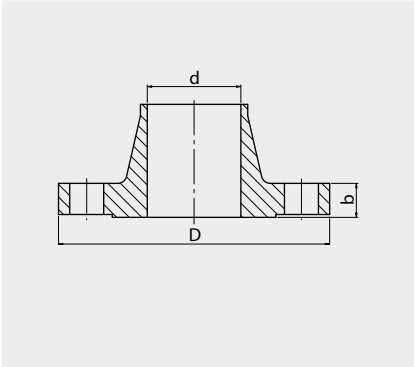

Size	Flange \varnothing D [mm]	Inside \varnothing d [mm]	Flange thickness b [mm]
DN10	90	13.6	16
DN15	95	17.3	16
DN20	105	22.3	18
DN25	115	28.5	18
DN40	150	43.1	18
DN50	165	54.5	20
DN65	185	70.3	22
DN80	200	82.5	24
DN100	235	107.1	24

Flange Ansi 300 lbs B 16.5

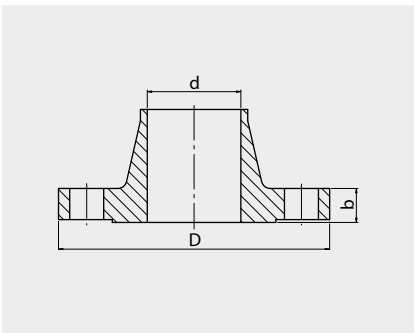

Size	Flange \varnothing D [mm]	Inside \varnothing d [mm]	Flange thickness b [mm]
½"	95.2	15.7	14.2
¾"	117.3	20.8	15.7
1"	124.0	26.7	17.5
1½"	155.4	40.9	20.6
2"	165.1	52.6	22.4
2½"	190.5	62.7	25.4
3"	209.6	78.0	28.4
4"	254.0	102.4	31.8