



3DLevelScanner II

TECHNICAL DATA SHEET



*Changing the market
from level to volume*

APM's 3DLevelScanner™

incorporates advanced technology for accurately measuring bulk solids and powder stored in silos and open bins of all types.



OVERVIEW

Theory of operation

The APM 3DLevelScanner II is the only device presently available that delivers accurate measurement of bulk solids and powders - regardless of the type of material or product characteristics, type and size of storage silo, bin or container, and harshness of the storage environment.

The 3DLevelScanner II employs an array of three antennas to transmit low frequency pulses and to receive echoes of the pulses from the contents of the silo, bin or other container. Using three antennas the unit measures not only the time/distance of each echo but also its direction. The device's Digital Signal Processor samples and analyzes the received signals to provide very accurate measurements of the level and volume of the stored contents, and generates a 3D representation of actual allocation of product within the container for display on remote computer screens. It incorporates APM's unique dust-penetrating technology to achieve an unrivalled degree of process measurement and inventory control.

3-D Mapping

- This unique device measures practically any kind of material stored in a large variety of containers, including silos, large open bins, bulk solid storage rooms, stockpiles and warehouses. It maps build-up loads and other irregularities that randomly form over time, offering solutions for this and many other previously inaccessible challenging applications.
- 3D representation of the stored contents for display on a remote computer screen.

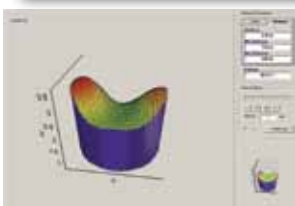
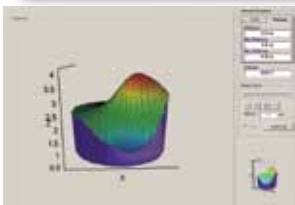
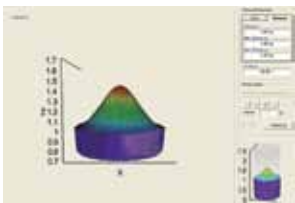

Display

Easy navigation
LCD with 4-button operation

Same housing for all versions
(Ex and non-Ex)



4-wire 4...20mA/HART/
RS485/Modbus

Key Specifications

Preferred application:	Solids
Measuring range:	70 m
Process fitting:	Thread, Flange, Mounting Strap
Process temperatures:	-40...+85°C (-40...+185°F)
Process pressure:	-0.2...1 bar (-2.9...14.5 Psi)
Signal output:	4-wire 4...20mA/HART/RS485/Modbus
Emitting frequency:	3 kHz to 10 kHz



TECHNICAL DATA

3DLevelScanner II

Materials, non-wetted parts

Housing	Painted aluminum die casting
Inspection window in housing	Polycarbonate
Antenna	Painted aluminum die casting
Flange	Steel

Weight

5.6 kg	Thread version
--------	----------------

Output variable

Output signal	4 ...20mA/HART/RS485/Modbus
Resolution	10 μ A
Fault signal	Current output unchanged, 22 mA, >3.6 mA (adjustable)
Current limitation	22 mA

Load

4-wire sensor	Max. 500 Ohm
---------------	--------------

Ambient conditions

Ambient, storage and transport temperature	-40...85°C (-40...+185°F)
Relative humidity	20...85%
Altitude	5,000 m (16,400 ft)

Process conditions

Vessel pressure	-0.2...1 bar (-2.9...14.5 Psi or -20...100 kPa)
-----------------	---

Process temperature

Measured on the process fitting	-40...+85°C (-40...+185°F)
Vibration resistance	Mechanical vibrations with 2g and 5...200 Hz

Electromechanical data

Cable entry/plug	1 x cable entry M20x1.5 (cable-Ø 8...12mm)
	1 x blind stopper M20x1.5
	Or
	2 x cable entry ½ NPT

Display panel

LCD	4 lines x 20 characters
Adjustment elements	4 keys
Protection	IP67

TECHNICAL DATA

Power supply – 4-wire instrument (Active) 4...20 mA / HART

Supply voltage 20 ...32 VDC

Power consumption max 4 VA; max 3 W

Electrical protective measures

Protection IP67 according to IEC 60529

Approvals

ATEX ATEX II 1/2D, 2D, Ex ibD/iaD 20/21 T110°C

ATEX II 2G Ex ia/ib IIB T4

FM FM Intrinsically Safe CL I,II, DIV I, GP CDEFG

CSA cCSAus Intrinsic Safety (pending)

IECEX IEC EEx ia IIC T6 (pending)

CE

EMC

Emission EN 61326:1997 (class B)

Susceptibility IEC / EN 61326:1997 + A1:1998 + A2:2001 + A3:2003

NSR (73/23/EWG) EN 61010-1:2001

FCC

Conformity to part 15 of the FCC regulations

FCC 47 CFR part 15:2007, subpart B, class A

Measurement characteristics

Frequency 3 - 10 kHz

Beam angle 30 - 70 degrees

Accuracy

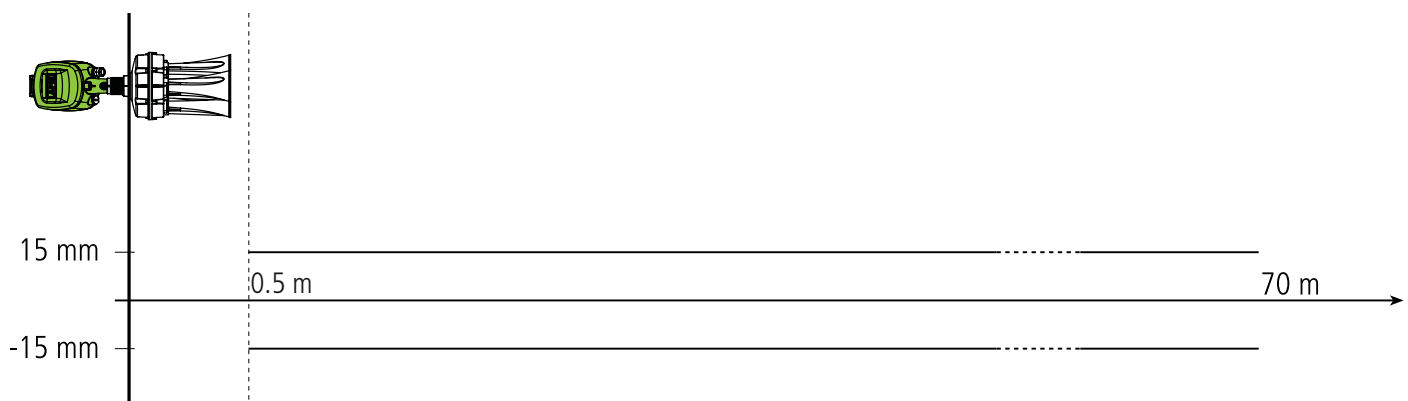



ELECTRICAL CONNECTION

General Requirements

The power supply range can differ depending on the instrument version. See the Technical Data section for full details.

In hazardous areas you should take note of the appropriate regulations, conformity and type of approval certificates of the sensors and power supply units.

Power Supply

4 ...20 mA/HART 4-wire

Power supply and signal current are carried on two separate connection cables. The output signal is active, hence the PLC must be configured passive.

Connection Cable

An outer cable diameter of 8 ...12 mm ensures the seal effect of the cable entry. If electromagnetic interference is expected, we recommend the use of screened cable for the signal lines.

Wiring Plans

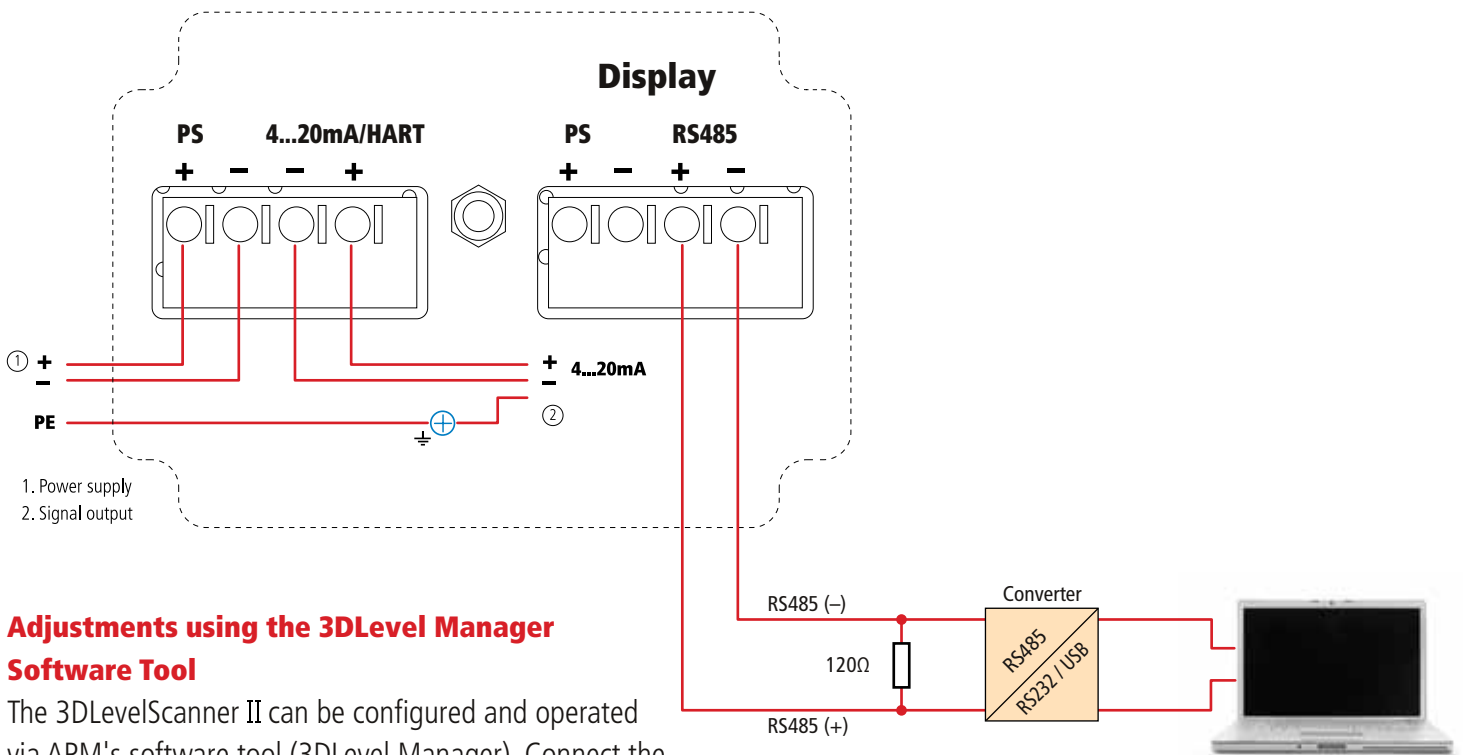

Adjustments using the 3DLevel Manager Software Tool

The 3DLevelScanner II can be configured and operated via APM's software tool (3DLevel Manager). Connect the 3DLevelScanner II according to the above diagram.

DIMENSIONS

3DLevelScanner II with horn antenna in flange version

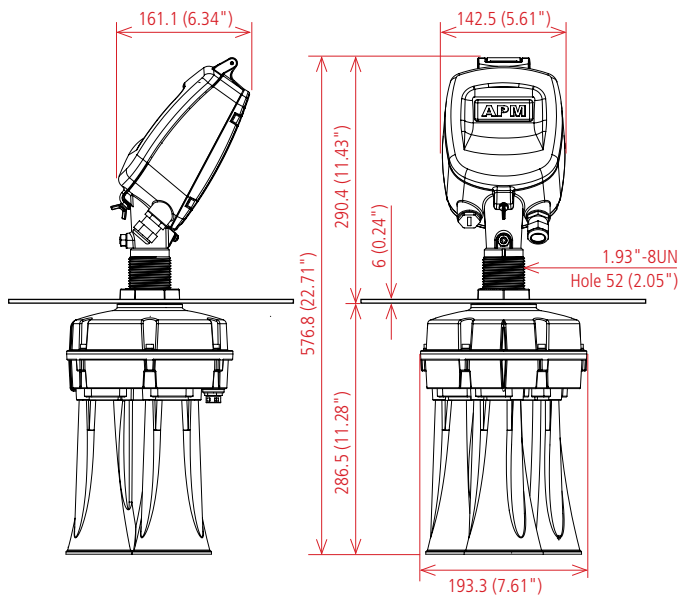

3DLevelScanner II with horn antenna in threaded version

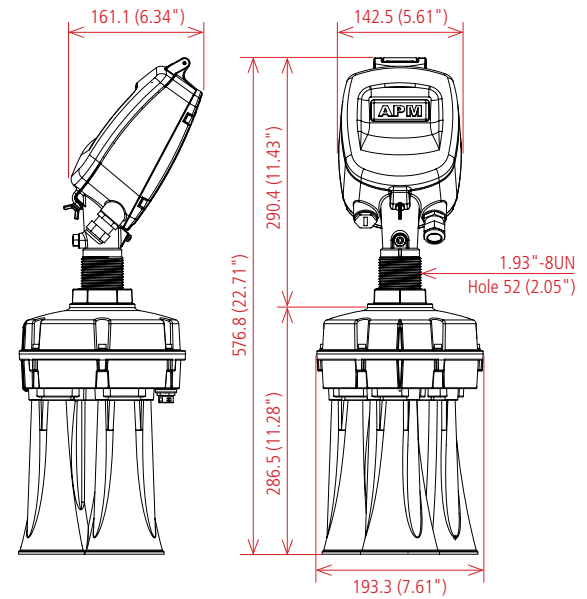

3DLevelScanner II Housing

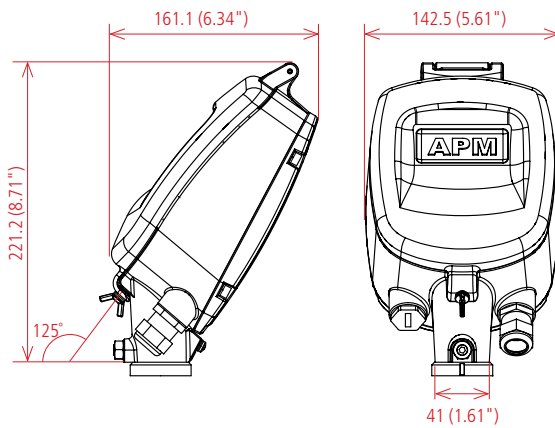

Dimensions in mm (inch)

OPERATION

3DLevelScanner II

Adjustments Using the LCD Panel

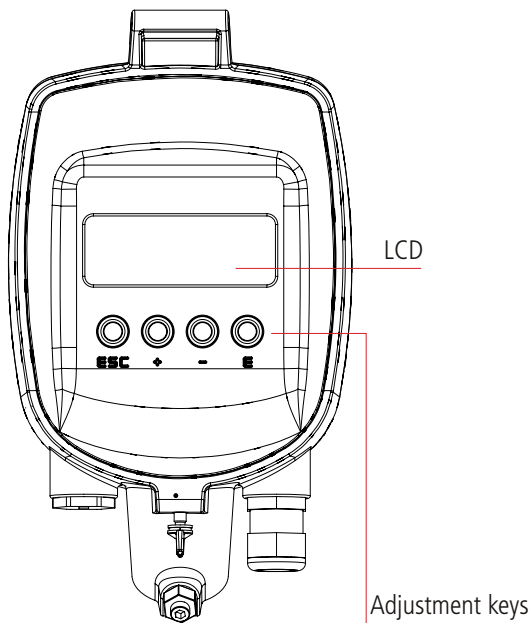

ESC	Navigate to the left within a function group; press ESC for 3 sec to go back to the basic screen
+	Navigate upwards in the selection list; edit numeric value within a function
-	Navigate downwards in the selection list; shifts to the right within a function
E	Navigate to the right within a function group; confirmation
+ and E	Increase contrast settings of the LCD
- and E	Decrease contrast settings of the LCD
+ and - and E	Hardware lock/unlock After a hardware lock, operation of the instrument via display or remote communication is not possible. The hardware can only be unlocked via the display, and an unlock parameter must be entered to do so. The display continues – uninterrupted. When all three buttons are pressed the display writes: "Hardware locked". When all three buttons are pressed again the display asks for "unlock parameter".

Volume Accuracy

Volume Accuracy - 3DLevelScanner II M/MV

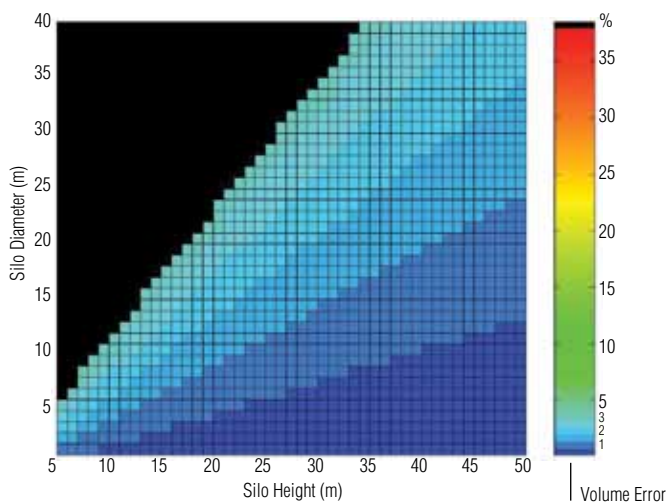

Volume Accuracy of a single point device

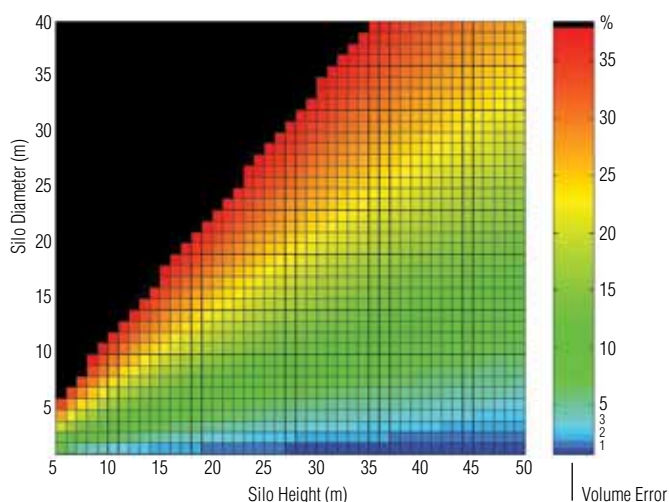

3DLevelScanner II

Type

S For solid applications

M For solid applications with mapping capabilities

MV For solid applications with mapping capabilities and visualization graphics tool

Approvals

XX Without

DX ATEX II 1/2D, 2D, Ex ibD/iaD 20/21 T110°C

GX ATEX II 2G Ex ia/ib IIB T4

FX FM Intrinsically Safe CL I,II, DIV I, GP CDEFG

Version / Material

B With horn antenna @195mm/ALU

Process connection

GD Thread 1.93" - 8 UN

FE Flange DN200

FG Flange DN250

AD Flange 6" 150lb RF, ANSI B16.5 / 316L

AE Flange 8" 150lb RF, ANSI B16.5 / 316L

AF Flange 10" 150lb RF, ANSI B16.5 / 316L

Electronics

V 4 ...20mA/HART – 4-wire/RS485/Modbus

Cable entry / Plug connection

M M20x1.5 / without

N 1/2 NPT / without

Neck Extension

A Without

B 200 mm

C 300 mm

D 400 mm

3DLevelScanner