

# MicroTREK

## GUIDED MICROWAVE LEVEL TRANSMITTERS



- ◆ Most advanced technology for measuring the level of liquids and solids
- ◆ Measurement is independent of dielectric constant, temperature, pressure and density variations
- ◆ Turbulent product surfaces, dust, vapour and foam have no effect on results
- ◆ Calibration with medium is not required
- ◆ "Easy-to-modify" probe length
- ◆ Two-wire loop-powered electronics
- ◆ High accuracy, repeatability and resolution
- ◆ Suitable for all tank shapes, especially for narrow vessels
- ◆ Measuring range: up to 24 m
- ◆ Accuracy:  $\pm 5\text{mm}$  for liquids
- ◆ Medium temperature:  $-30\text{ }^{\circ}\text{C} \dots +200\text{ }^{\circ}\text{C}$
- ◆ Pressure: up to 40 bar

## ABOUT THE MICROTREK

MicroTREK level gauge operates based on the well known TDR (Time Domain Reflectometry) principle which is commonly used as a discontinuity test of cables.



Micropulses are sent along a probe guide at the speed of light. As soon as the pulse reaches the surface of the medium, it is reflected back to the electronic module. Level distance is directly proportional to the flight time of the pulse.

The TDR technology is unaffected by the properties of the medium as well as that of the space above it.

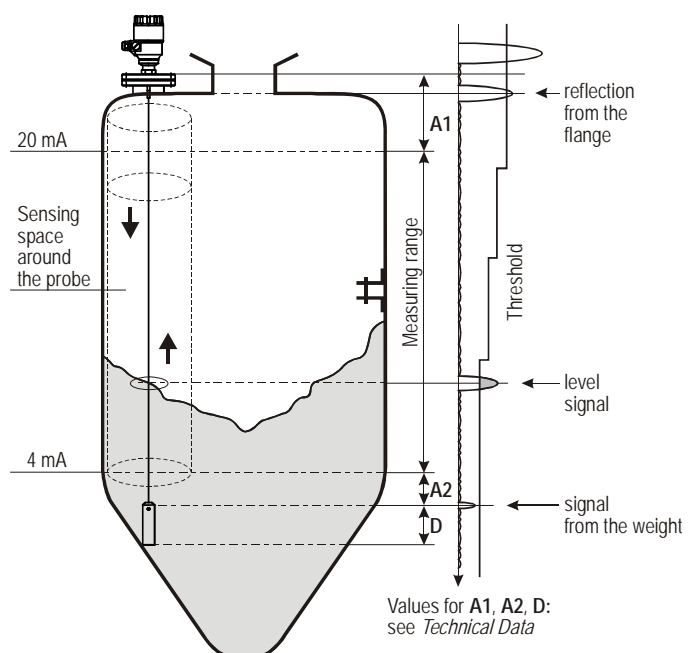
The measured level data is converted into 4-20 mA current and HART signals and can be processed using our MULTICONT remote HART controller. The transmitter can be configured using a PC via a HART-modem. As a result, the measuring range, the threshold position and the linearisation function (a maximum of 20 Points) can be changed via the computer.



# TECHNICAL DATA

TYPE		MONO-ROD	MONO-CABLE	TWIN CABLE	TWIN ROD	COAXIAL PIPE
Range m (feet)		≤ 3 (9.84)	≤ 24 (78.74)	≤ 24 (78.74)	≤ 3 (9.84)	≤ 6 (19.69)
Dead zone ( $\epsilon_r = 80$ )	Top m (feet) [see A1 in Fig.1]	0.40 (1.31)	0.40 (1.31)	0.30 (0.98)	0.25 (0.82)	0 (0)
	Bottom m (feet) [see A2 + D in fig. 1]	0.02 (0.07)	0.02 (0.07) + counterweight length	0.02 (0.07) + counterweight length	0.02 (0.07)	0.01 (0.03)
Reference conditions		Highly reflective product (e.g. water), calm surface, mounted at least 0.3 m (0.98 ft) away from the tank wall, +20 °C (+68 °F), 1013 mbar abs. (14.5 psig), 65% rel. humidity				
Error of measurement	4... 20 mA	± 0.01% related to the measured value				
	for liquids	± 5 mm (0.02 ft) for probe length ≤ 15 m (49,21 ft) ; ±0.05% of probe length > 15 m (49.21 ft)				
	for solids	± 20 mm (0,05 ft)				
Temperature drift (HART, Current)		0.01% /K, 0.5 µA / K				
Repeatability		± 2 mm				
Output		Analogue: 4 ... 20 mA with digital communication: HART (Fault indication: 22 mA)				
Power supply		18 ... 35 V DC (< 28 V DC with the Ex version)				
Temperature ranges	Process	-30 °C ... + 200 °C (when the flange temperature limits for the standard unit is strictly adhered to)				
	Flange	standard: -30 °C ... + 90 °C; high temperature version: up to 200 °C (up to 150 °C for Ex)				
	Ambient	-30 °C ... + 60 °C (up to 55 °C for Ex)				
Pressure		maximum 40 bar (4.0 MPa) – can be restricted by pressure rating of the process connection used				
Dielectric constant of the medium		$\epsilon_r \geq 2.3$		$\epsilon_r \geq 1.8$		$\epsilon_r \geq 1.5$
Electrical connections	Wire cross section:	maximum 1.5 mm <sup>2</sup>				
	Conduit:	M20 x 1.5 cable glands (2 pcs., attached as accessories) and 2 pcs. ½" NPT (closed by closing screws)				
Probe diameter, probe material and coating material spacer material		Ø 8 mm 1.4571 - -	Ø 4 mm, Ø 8 mm 1.4401, FEP (for Ø 4 mm probe only) -	2 x Ø 4 mm 1.4401 - FEP	2 x Ø 8 mm 1.4401 - PTFE	Ø 28 mm 1.4571 - PTFE
Max. tensile load		1 t	1 t (for Ø 4 mm) 3,5 t (for Ø 8 mm)	1 t	1 t	-
Smallest available process connection		1" BSP, 1" NPT	1" BSP, 1" NPT for Ø4 mm 1"½ BSP, 1"½ NPT for Ø8 mm	1"½ BSP, 1"½ NPT	1"½ BSP, 1"½ NPT	1" BSP, 1" NPT
Housing material / mass		Aluminium, paint coated / 2 kg without probe				
Gaskets		FPM, EPDM, FFKM, others on special request				
Ex approvals		ATEX  II 1G EEx ia IIC T6...T3 for units with stainless steel probe, ATEX  II 1G EEx ia IIB T6...T3 for units with plastic covered probe, ATEX  II 1/2D T100°C for Dust Ex applications				
Ingress protection		IP 65 (NEMA 4)				

## PROBE SELECTION

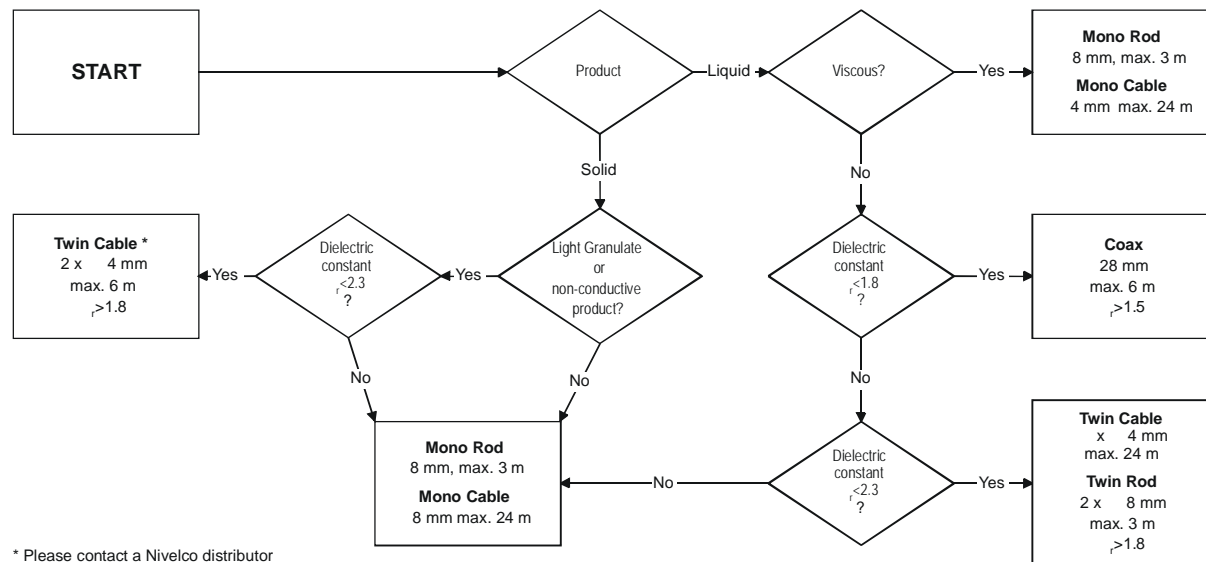

# DIMENSIONS

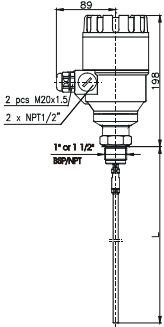
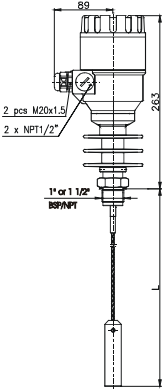
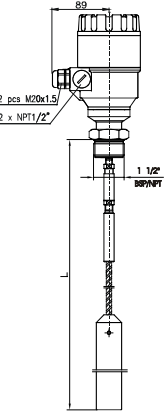
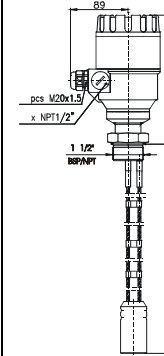
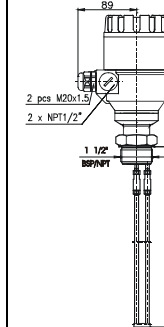
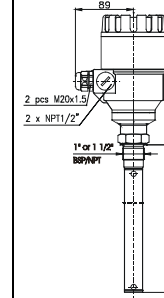
MicroTREK H versions						
Counterweight	none	Ø25 x 100 mm	Ø40 x 260 mm	Ø40 x 80 mm	none	none
Minimal process connection	1" BSP 1" NPT	1" BSP 1" NPT	1" ½ BSP 1" ½ NPT	1" ½ BSP 1" ½ NPT	1" ½ BSP 1" ½ NPT	1" BSP 1" NPT
Description	RIGID Ø 8 MM MONO ROD PROBE STANDARD TEMPERATURE VERSION	FLEXIBLE Ø 4 MM MONO CABLE PROBE HIGH TEMPERATURE VERSION	FLEXIBLE Ø 8 MM MONO CABLE PROBE STANDARD TEMPERATURE VERSION	FLEXIBLE 2 x Ø 4 MM TWIN CABLE PROBE STANDARD TEMPERATURE VERSION	RIGID 2 x Ø 8 MM TWIN ROD PROBE STANDARD TEMPERATURE VERSION	RIGID Ø 28 MM COAXIAL PROBE STANDARD TEMPERATURE VERSION

# APPLICATIONS

	MONO CABLE MONO ROD	TWIN CABLE	TWIN ROD	COAXIAL PIPE
<b>MAIN APPLICATIONS</b>	<ul style="list-style-type: none"> <li>◆ Cement, limestone, fly ash, alumina, carbon black</li> <li>◆ All high-viscosity liquids</li> <li>◆ Mineral powders</li> <li>◆ Water storage tanks</li> </ul>	<ul style="list-style-type: none"> <li>◆ Tank parks with solvents, oil or fuels</li> </ul>	<ul style="list-style-type: none"> <li>◆ Plastic granule vessels</li> <li>◆ Process vessels</li> </ul> <p>Applications without anchoring the probe end</p>	<ul style="list-style-type: none"> <li>◆ Small vessels or tanks with max. 6 m (19.69 ft) height</li> <li>◆ Solvents, liquefied gases</li> <li>◆ LPG, LNG</li> </ul>
	FOR CLEAN AND CONTAMINATED LIQUIDS OR POWDERS AND BULK SOLIDS	FOR HIGH SILOS OR TANKS WITH LIQUIDS OR LIGHT GRANULES	FOR CLEAN AND CONTAMINATED LIQUIDS OR FINE POWDERS	FOR CLEAN LIQUIDS
<b>RECOMMENDED IN THE FOLLOWING CASES:</b>	<ul style="list-style-type: none"> <li>◆ For all viscous liquids</li> <li>◆ For stilling wells (calibration required)</li> <li>◆ For food applications with FEP coating</li> <li>◆ Slightly conductive foams</li> <li>◆ High temperature applications without spacers</li> <li>◆ For products with low dielectric constant (<math>\epsilon_r &gt; 2.3</math>)</li> </ul>	<ul style="list-style-type: none"> <li>◆ Up to 24 m (80 ft)</li> <li>◆ For tanks with little head clearance</li> <li>◆ For small nozzles</li> <li>◆ For products with low dielectric constant (<math>\epsilon_r &gt; 1.8</math>)</li> <li>◆ Close to wall mounting possible</li> </ul>	<ul style="list-style-type: none"> <li>◆ Up to 3 m (10 ft)</li> <li>◆ For tanks with little head clearance</li> <li>◆ For products with low dielectric constant (<math>\epsilon_r &gt; 1.8</math>)</li> <li>◆ For narrow vessels</li> <li>◆ For slightly moving products</li> </ul>	<ul style="list-style-type: none"> <li>◆ Agitated or flowing liquids – the probe acts as a stilling well</li> <li>◆ Liquid or vapour spray near the probe</li> <li>◆ Can be heated</li> <li>◆ Contact possible with metallic object or tank wall</li> <li>◆ For very low <math>\epsilon_r</math> liquids (<math>\epsilon_r &gt; 1.5</math>)</li> </ul>
<b>AVOID:</b>	<ul style="list-style-type: none"> <li>◆ Small nozzle diameters</li> <li>◆ High nozzle heights</li> <li>◆ Abrasive solids with grain size &gt; 15 mm</li> </ul>	<ul style="list-style-type: none"> <li>◆ Agitated liquids without probe anchoring</li> <li>◆ Product temperature <math>T &gt; 150</math> °C (max. limit with optional FEP spacers)</li> <li>◆ Applications with solids</li> <li>◆ Conductive build up bridge on spacers</li> </ul>	<ul style="list-style-type: none"> <li>◆ Agitated vortical liquids</li> <li>◆ Conductive build up bridge on spacers</li> </ul>	<ul style="list-style-type: none"> <li>◆ Crystallizing liquids</li> <li>◆ Liquids with solid particles</li> <li>◆ Adhesive products</li> <li>◆ Powders</li> <li>◆ Viscous fluids (e.g. crude oil)</li> <li>◆ Product temperature <math>T &gt; 150</math> °C (max. limit with PTFE spacers)</li> </ul>



## WIRING

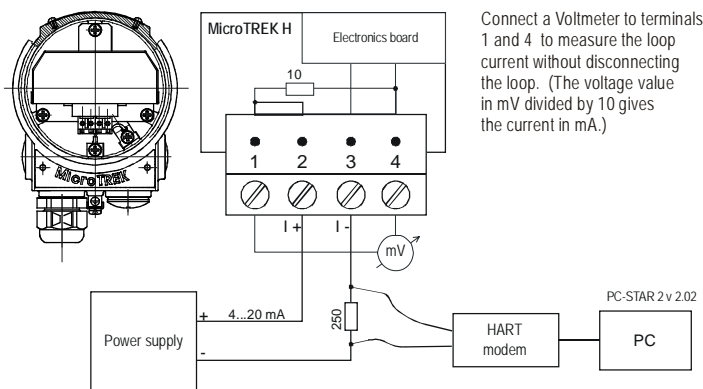

Connect a Voltmeter to terminals 1 and 4 to measure the loop current without disconnecting the loop. (The voltage value in mV divided by 10 gives the current in mA.)

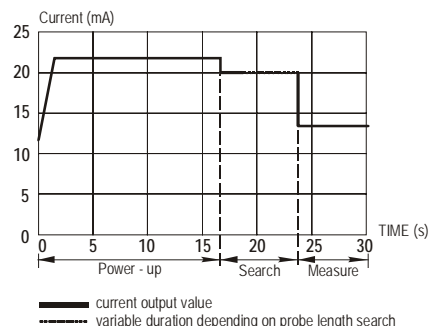

When MicroTREK is switched on the current output stays at 22 mA for 15 seconds. The analogue output subsequently indicates a value between 4 and 20 mA until the level has been found. After a maximum of 23 seconds, the current output indicates the measured level and follows it.

## INSTALLATION

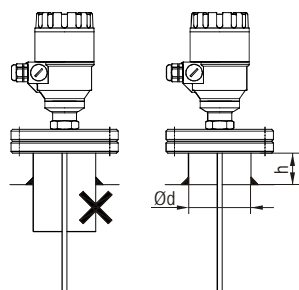

Probe-specific minimal distances from tank wall:  
 Mono probe > 300 mm  
 Twin probe > 100 mm  
 Coaxial probe > 0 mm

The recommended ratio of the height and the diameter of the nozzle:  $h \leq \varnothing d$

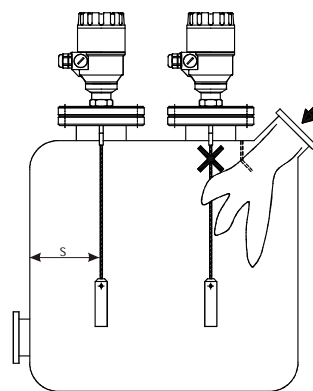

## ORDER CODES (NOT ALL COMBINATIONS ARE POSSIBLE)

MicroTREK H [ ] [ ] - [ ] [ ] - [ ] Ex\*\*

TYPE	CODE	PROBE / PROCESS CONNECTION	CODE	HOUSING	CODE	PROBE LENGTH			OUTPUT / APPROVAL	CODE	
Transmitter	T	Coaxial / 1" BSP	A	Aluminium	2	0	0 m	0,0 m	0	4-20 mA + HART / none	4
Transmitter + display	C	Coaxial / 1" NPT	B	Plastic PBT*	3	1	1 m	0,1 m	1	4-20 mA + HART / por Ex	6
		Coaxial / 1 1/2" BSP	C			2	2 m	0,2 m	2	4-20 mA + HART / EExia	8
		Coaxial / 1 1/2" NPT	H			3	3 m	0,3 m	3		
		Mono rod / 1" BSP	R			4	4 m	0,4 m	4		
		Mono rod / 1" NPT	P			5	5 m	0,5 m	5		
		Mono rod / 1 1/2" BSP	S			6	6 m	0,6 m	6		
		Mono rod / 1 1/2" NPT	Z					0,7 m	7		
		Twin rod / 1 1/2" BSP	D					0,8 m	8		
		Twin rod / 1 1/2" NPT	E					0,9 m	9		
		4 mm Mono cable / 1" BSP	K			MONO CABLE					
		4 mm Mono cable / 1" NPT	L			0	0 m	0 m	0		
		4 mm Mono cable / 1 1/2" BSP	V			1	10 m	1 m	1		
		4 mm Mono cable / 1 1/2" NPT	W			2	20 m	2 m	2		
		8 mm Mono cable / 1 1/2" BSP	N					3 m	3		
		8 mm Mono cable / 1 1/2" NPT	J					4 m	4		
		4 mm Twin cable / 1 1/2" BSP	T					5 m	5		
		4 mm Twin cable / 1 1/2" NPT	U					6 m	6		
		4 mm FEP Mono cable / 1" BSP	F					7 m	7		
		4 mm FEP Mono cable / 1" NPT	G					8 m	8		
		4 mm FEP coated Mono cable / DN40 Triclamp	X					9 m	9		
		4 mm FEP coated Mono cable / DN40 Milch	Y								

\* Under development

\*\* Ex certified units will be marked with the 'Ex' mark added to the order

Technical specification may be changed without notice