



Simple. Rugged. Reliable.

- Triple thread screw on/off cover - No more bolts!
- Immune from product build-up on probe
- Unsurpassed sensitivity and stability
- No interference from RF signals
- Switch selectable high/low fail-safe
- "Quick-Set" calibration
- Dual conduit entrance for improved wiring access
- Hazardous location approval standard
- Wetted parts are all 316 stainless steel
- Powder coat finish

PROCAP Capacitance Level Sensors

BINMASTER[®]

www.binmaster.com

PROCAP Series

Introduction

No plant equipment interference from RF signals

New innovative design

The PROCAP Series capacitance probes use advanced integrated circuit technology operating at low frequency to achieve both high sensitivity and stable calibration. The probe uses a simple timing technique that compares the discharge time of the probe capacitance to that of a reference capacitance. The probes outstanding stability results from several factors. (1) A single integrated circuit makes the critical timing comparison. Temperature variations have an equal effect on the timing of both the probe and reference capacitance and, therefore, cancel. (2) The time interval at which the discharge comparison is repeated is not involved in the sensing process, making calibration independent of oscillator frequency and stability. (3) Both the probe and the reference capacitance discharge are from a common voltage level. This makes calibration insensitive to power supply voltage variations. (4) Equal internal capacitance in both the probe and reference circuitry make any temperature dependent changes to these components values cancel. In addition, these internal capacitors have zero temperature coefficients and are physically located together to assure they are at equal temperatures. Calibration stability, along with, static discharge survival, and RF immunity are three of the main reasons why BinMaster probes outperform the competition.

No plant interference from using radio frequency signals

BinMaster's PROCAP Series capacitance sensors provide high sensitivity and accurate level detection without using radio frequency (RF) signals. According to the Federal Communications Commission, signals in excess of 9 KHz are classified as "RF" and are prone to radiate. Competitive capacitance sensors which emit RF signals may interfere with nearby electronic plant equipment. Conversely, some competitive sensors utilizing RF are themselves susceptible to interference from other RF sources and may not function properly when a device such as a two way radio is operated near them. The BinMaster PROCAP Series is completely immune to such interference issues.

"Quick-Set" Calibration

Calibrating PROCAP Series sensors is made simple and precise with the Quick-Set design using two single turn potentiometers. One labeled "course" is used to compensate for the capacitance of the empty vessel. The other potentiometer labeled "fine" is set to the desired sensitivity for the vessel material. However, material does not need to be present when calibrating PROCAP Series sensors. And that's it. Two quick turns and the sensor will maintain precise calibration and dependable operation even throughout extreme climate changes.

Principle of operation

BinMaster's PROCAP Series capacitance sensors read the presence or absence of material in contact with the probe by sensing a change in capacitance caused by the difference in the dielectric constant of the vessel material and air. These sensors must be able to sense very small changes in capacitance, typically one picofarad. To sense such a small capacitance change, competitive manufacturers often use electronic circuits incorporating frequency shift oscillators and balanced bridges that must operate at high frequencies in the RF range. Most capacitance sensor manufacturers use frequencies between 100 KHz and 2 MHz.

BinMaster's PRO Series use a unique discharge time constant detector circuit which allows sensing capacitance changes less than one picofarad without the need for radio frequencies. PROCAP Series capacitance sensors operate at approximately 6 KHz, well below the RF level and therefore are not subject to FCC regulation. Plus, because the PROCAP Series sensors operate at such a low frequency, they will not interfere with nearby electronic plant equipment and are not susceptible to interference from other equipment.



Accurate & reliable level detection
even in the harshest conditions

PROCAP Series

Quality Construction, Improved Performance

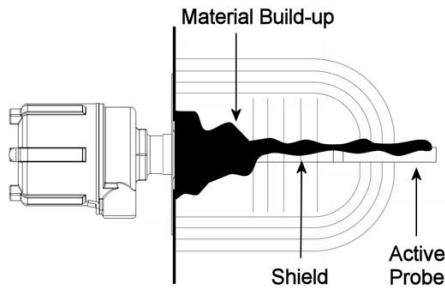

Pro-Shield Prevents False Readings

PROCAP Series sensors feature PRO-Shield to guard against false readings from build-up on the probe or bridging between the sidewall and the probe. The shield is a portion of the probe that emits a non-sensing signal that forces the active signal to examine a large area around the probe. The PRO-Shield allows the PROCAP Series sensors to be used in vessels storing a wide variety of dusty, sticky, or clinging materials.

Time Delay Minimizes False Signals

The PROCAP Series time delay feature minimizes false signals from sudden material shifts or splashing liquids caused by process activities. The time delay operates by "delaying" a set period of time prior to acknowledging the signal for a change in the presence or absence of material. The time delay is simple to adjust and may be set up to 30 seconds.

New Fail-Safe Protection Eliminates Process Accidents

PROCAP series capacitance sensors feature fail-safe protection to eliminate process accidents caused by a power failure. A high/low selectable switch allows the sensor to be set for fail-safe high or fail-safe low.

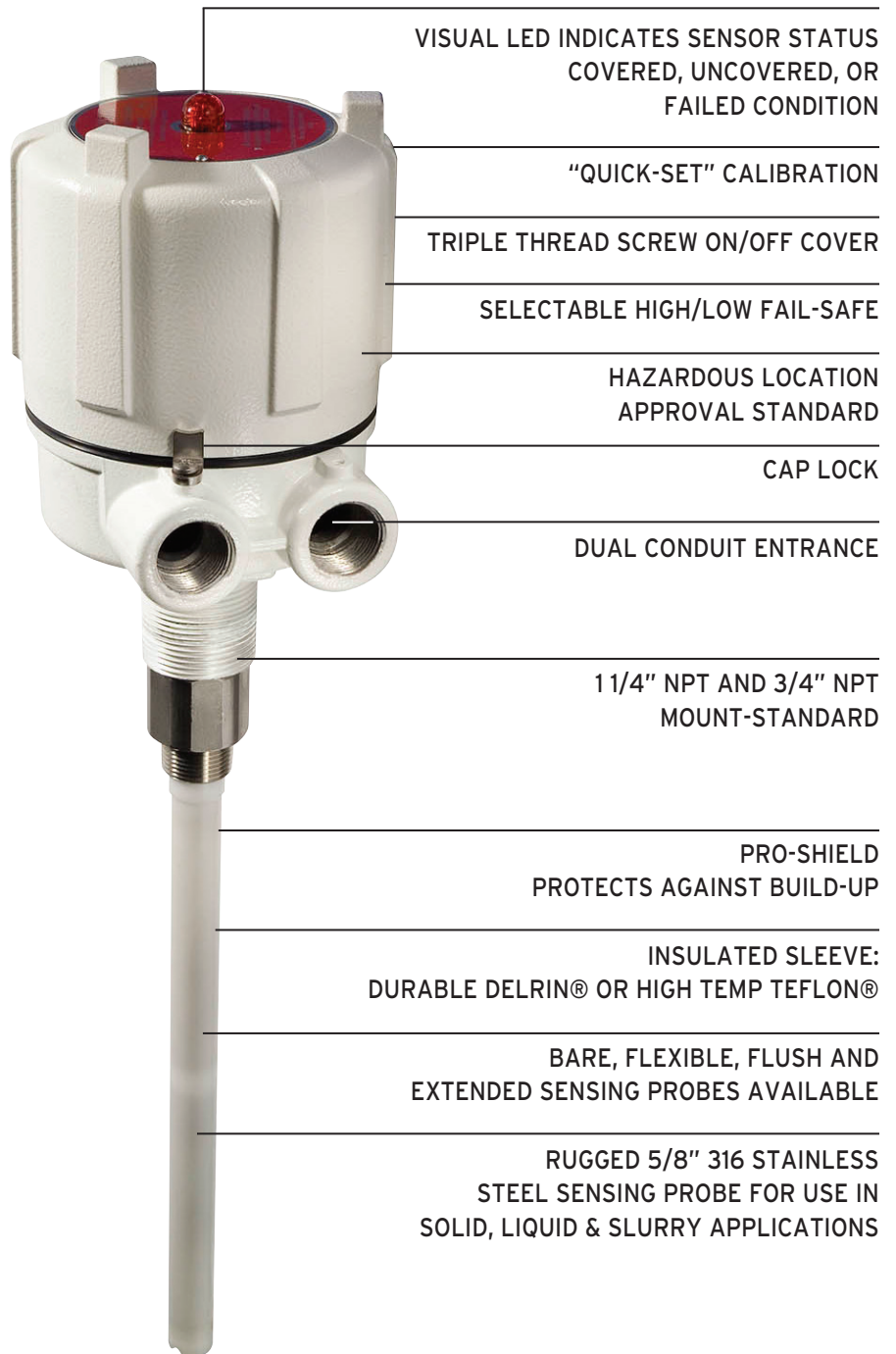

PROCAP Series

High Performance, Many Applications

Modular Design with a wide range of configurations

Applications

BinMaster's PROCAP Series capacitance sensors are designed for industries' wide array of applications. PROCAP Series sensors may be used in solid, liquid and slurry materials. The sensors may be used for high and low level detection in bins, silos, tanks, hoppers, chutes and other vessels where material is stored, processed or discharged.

Detects Wide Range of Materials

Capacitance sensors are calibrated based on the dielectric constant of the material being detected. BinMaster's PROCAP Series sensors may be easily calibrated for detecting material with a dielectric constant ranging from 1.5 picofarad and greater. With the simple to use "Quick-Set" calibration, you can quickly set the PROCAP Series sensor to detect your material in just a few seconds!

Common PROCAP Series Material Applications

Calcium	Grains
Cement	Oils
Coal	Paints
Chemicals	Paper Pulp
Feed	Pellets
Fly Ash	Plastics
Food	Pharmaceuticals
Rubber	Sand



Extended Models

The flexible cable extension probe was designed for high, mid or low level detection when it is necessary to top mount. This probe is also very effective in aggregate, coal, or other lump materials that might damage a rigid probe. Maximum length of the cable is 35 feet. Cable can be cut to length in the field.

Sanitary Models

Sanitary versions for the food and pharmaceutical industries feature no threads and a tri-clamp connection. These units are 3-A/USDA compliant and are food grade safe. Units are designed to operate in clean-in-place (CIP) applications in the food industries.



Flush Mounted Models

This probe was designed for space constrained areas or applications where material flow or bridging may damage standard probes. The probe mounts flush on a vessel wall, conveyer housing or chute.



PROCAP Advantages

Mounting Flexibility, Various Configurations



OEM Models

The new shielded, bare stainless steel probe was designed to allow customers to purchase one standard probe and adjust the length in the field. The probe can be cut down to 8" or extended to 8'. This will reduce cost, decrease lead times, and allows you to stock one probe.

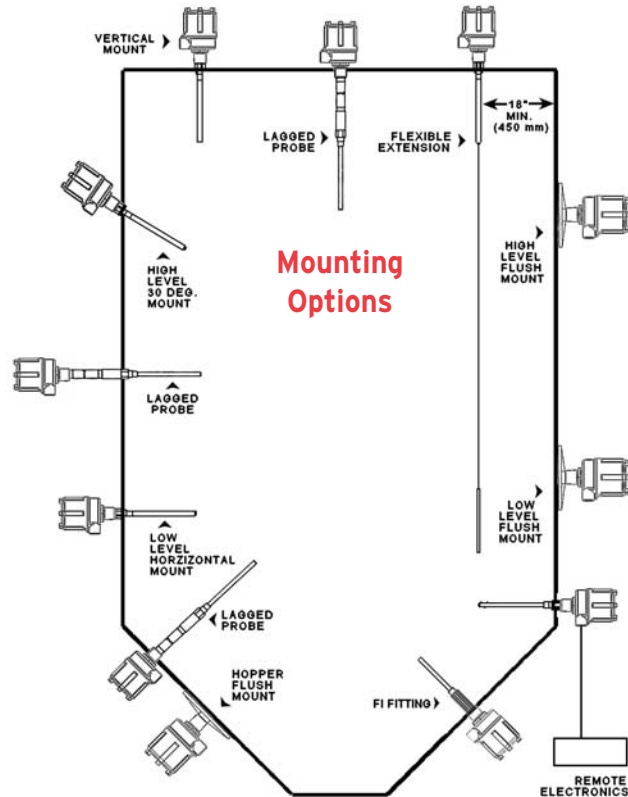

Remote Electronics

Specially designed for hostile applications with high temperature or vibration. The probe and electronics are housed in separate enclosures. With this unique "split" configuration, the sensor's electronics may be safely mounted up to 75' from the sensing probe.



Hazardous Locations

PROCAP IX & IIX capacitance sensors are specially designed for hazardous location applications. The sensor housing is explosion proof: Class I, Group C, D and Class II, Group E, F, G. This model is available with a standard or flush mount sensing probe.



Auto-Calibration

The PRO AUTO-CAL calibration procedures take seconds and can be performed right through the unit's cover with the use of a magnet. This unit also allows you to simulate an either covered or uncovered condition without accessing the probe assembly or electronics.



PROCAP I & II

PROCAP IX & IIX

PROCAP I 3-A & II 3-A

Power PROCAP I:	24 to 240 VAC or VDC Universal Power Supply
Power PROCAP II:	115/230 VAC 50/60 Hz, 2.2VA
Output Relay:	DPDT 10 Amp at 250 VAC
Ambient Temperature Electronics:	-40°F to +185°F (-40°C to +85°C)
Probe:	250°F Delrin/Bare (121°C) 500°F Teflon (260°C)
Pressure:	500 PSI, 3/4" Mount
Sensitivity Setting:	Adjustable sensitivity to < 1 PicoFarad
Calibration:	"Quick Set" Course/Fine Single Turn Potentiometers
Fail-Safe:	Switch Selectable High/Low
Time Delay:	Adjustable up to 30 Seconds
Enclosure:	Die Cast Aluminum, Threaded Cover, USDA Approved Powder Coat Finish
Conduit Entry:	3/4" NPT
Mounting:	1 1/4" NPT or 3/4" NPT 316 SS
PRO-Shield:	Compensates for Material Build-up on Sensing Probe
Approval Rating:	☞ listed for Class II, Groups E, F & G Hazardous Locations. Enclosure Type NEMA 4X, 5, 9 & 12. CE Mark.
Status Indicator:	Visual LED Indicates Sensor Status: Uncovered, Covered, and Power Failure
Probe Options:	Delrin, Teflon, Food Grade, Flush Mount, Flexible Extension, Stubby Shielded, Extended Shielded, Bare Shielded, Lagged

Power PROCAP IX:	24 to 240 VAC or VDC Universal Power Supply
Power PROCAP IIX:	115/230 VAC 50/60 Hz, 2.2VA
Output Relay:	DPDT 10 Amp at 250 VAC
Ambient Temperature Electronics:	-40°F to +185°F (-40°C to +85°C)
Probe:	250°F Delrin/Bare (121°C) 500°F Teflon (260°C)
Pressure:	500 PSI, 3/4" Mount
Sensitivity Setting:	Adjustable sensitivity to < 1 PicoFarad
Calibration:	"Quick Set" Course/Fine Single Turn Potentiometers
Fail-Safe:	Switch Selectable High/Low
Time Delay:	Adjustable up to 30 Seconds
Enclosure:	Die Cast Aluminum, Threaded Cover, USDA Approved Powder Coat Finish
Conduit Entry:	3/4" NPT
Mounting:	1 1/4" NPT or 3/4" NPT 316 SS
PRO-Shield:	Compensates for Material Build-up on Sensing Probe
Approval Rating:	☞ listed for Class I, Groups C & D and Class II, Groups E, F & G, Hazardous Locations. Enclosure Type NEMA 4X, 5, 9 & 12. CE Mark.
Status Indicator:	Internal LED Indicates material In Contact With Probe
Probe Options:	Delrin, Teflon, Food Grade, Flush Mount, Stubby Shielded, Extended Shielded, Lagged

Power PROCAP I 3-A:	24 to 240 VAC or VDC Universal Power Supply
Power PROCAP II 3-A:	115/230 VAC 50/60 Hz, 2.2VA
Output Relay:	DPDT 10 Amp at 250 VAC
Ambient Temperature Electronics:	-40°F to +185°F (-40°C to +85°C)
Probe:	250°F Delrin (121°C)
Pressure:	200 PSI
Sensitivity Setting:	Adjustable sensitivity to < 1 PicoFarad
Calibration:	"Quick Set" Course/Fine Single Turn Potentiometers
Fail-Safe:	Switch Selectable High/Low
Time Delay:	Adjustable up to 30 Seconds
Enclosure:	Die Cast Aluminum, Threaded Cover, USDA Approved Powder Coat Finish
Conduit Entry:	3/4" NPT
Mounting:	1" or 2" Sanitary 316 SS Fitting
PRO-Shield:	Compensates for Material Build-up on Sensing Probe
Approval Rating:	☞ listed for Class II, Groups E, F & G Hazardous Locations. Enclosure Type NEMA 4X, 5, 9 & 12. CE Mark.
Status Indicator:	Visual LED Indicates Sensor Status: Uncovered, Covered, and Power Failure
Probe Options:	All Delrin Sleeved Style Probes



PROCAP I-FL & II-FL

Power PROCAP I-FL:	24 to 240 VAC or VDC Universal Power Supply
Power PROCAP II-FL:	115/230 VAC 50/60 Hz, 2.2VA
Output Relay:	DPDT 10 Amp at 250 VAC
Ambient Temperature Electronics:	-40°F to +185°F (-40°C to +85°C)
Probe:	150°F Standard (65°C) 450°F High Temp (232°C)
Pressure:	250 PSI, Flush Mount
Sensitivity Setting:	Adjustable sensitivity to < 1 PicoFarad
Calibration:	"Quick Set" Course/Fine Single Turn Potentiometers
Fail-Safe:	Switch Selectable High/Low
Time Delay:	Adjustable up to 30 Seconds
Enclosure:	Die Cast Aluminum, Threaded Cover, USDA Approved Powder Coat Finish
Conduit Entry:	3/4" NPT
Mounting:	Flush Mount Non-Invasive
PRO-Shield:	Compensates for Material Build-up on Sensing Probe
Approval Rating:	listed for Class II, Groups E, F & G Hazardous Locations. Enclosure Type NEMA 4X, 5, 9 & 12. Units also available in Class I, Groups C & D.
Status Indicator:	Visual LED Indicates Sensor Status: Uncovered, Covered, and Power Failure
Probe Options:	Flush Mounted Probe; Standard or High Temp



PRO REMOTE

Power Requirements:	120/240 VAC 50/60 Hz +15%, 5VA
Output Relay:	DPDT 10 Amp at 250 VAC STATUS Contacts: 3 Amps 240 VAC
Ambient Temperature Electronics:	-40°F to + 185°F (-40°C to +85°C)
Probe:	250°F Delrin/Bare (121°C) 500°F Teflon (260°C)
Pressure:	500 PSI, 3/4" Mount
Sensitivity Setting:	Adjustable Sensitivity to < 1 PicoFarad
Calibration:	"Quick Set" Coarse/Fine Single Turn Potentiometers
Fail-Safe:	Switch Selectable High/Low
Time Delay:	Adjustable .25 to 10 Seconds
Enclosure Probe:	Cast Aluminum, Bolt-On Cover USDA Approved Finish
Enclosure Electronics:	Plastic
Mounting:	1 1/4" NPT or 3/4" NPT 316 SS
PRO-Shield:	Compensates for Material Build-up on Sensing Probe
Approval Ratings Probe:	Listed NEMA 4X, 5 & 12 Intrinsically Safe
Electronics:	Listed Class II, Group E, F, & G NEMA 4X, 5 and 12
Status Indicator:	Internal LED Indicates Material In Contact With Probe
Probe Options:	Delrin, Teflon, Food Grade, Flush Mount, Flexible Extension, Stubby Shielded, Extended Shielded, Bare Shielded, Lagged



COMPACT PRO

Power Requirements:	120 VAC, 230 VAC, or 24VDC
Output Relay:	SPDT 5 amp at 250 VAC
Temperature Electronics:	-40 to 185° F (-40 to 85° C)
Probe:	-40 to 240° F (-40 to 116° C)
Enclosure:	NEMA 4X, Dust Tight, Water Resistant
Sensitivity Setting:	Adjustable sensitivity to <1 Picofarad
Calibration:	Multi-turn Potentiometer
Fail-Safe:	Switch Selectable, High/Low
Time Delay:	Adjustable 1 to 30 Seconds
Enclosure:	PVC
Probe:	CPVC
Mounting:	1" NPS (1 1/4" NPS Adapter available)
LED:	Indicates Material Presence or Absence

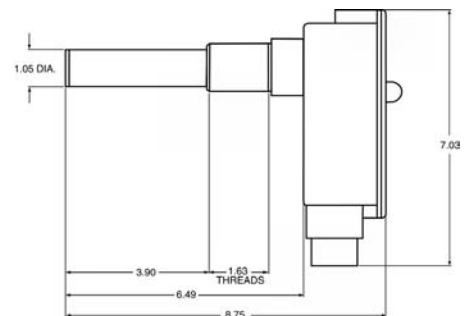

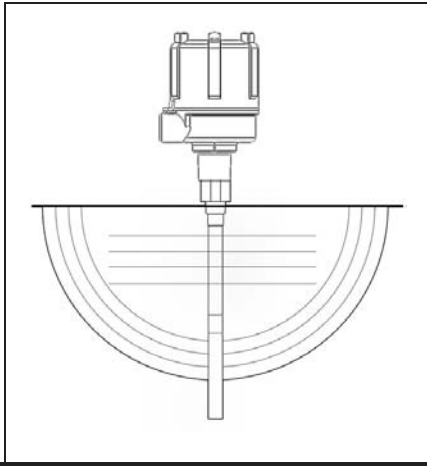

**Standard Shielded
Delrin/Teflon Sleeved Probe**

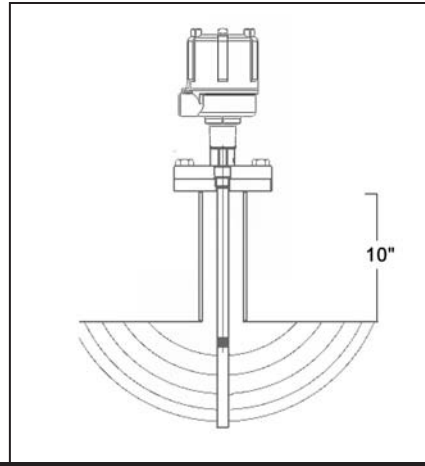

**Extended Shield Delrin/Teflon
Sleeved probe**

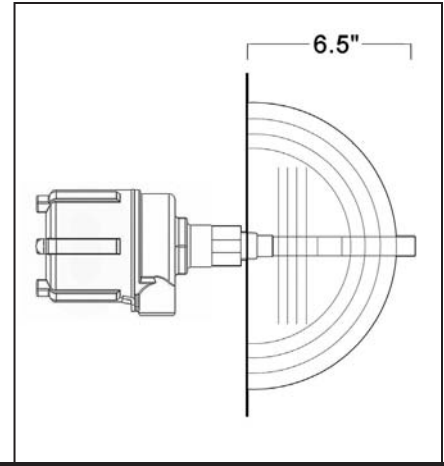

**Stubby Shielded
Delrin/Teflon Sleeved Probe**

The standard Delrin/Teflon sleeved probe is our most versatile all-purpose probe. It works reliably in bulk solids, powders, slurries, and liquids. It has a rugged 5/8" dia. 316 SS probe featuring "PRO-Shield" protection against false readings because of coating or buildup.

- Maximum Temp:** Delrin Sleeved
250° F. (121°C)
Teflon Sleeved
500° F. (260 C)
- Maximum Pressure:** 50 psi (3.5 kg/cm2)
1 1/4" NPT
500 psi (35 kg/cm2)
3/4" NPT
- Probe Material:** 5/8" dia. 316 SS
Delrin/Teflon sleeved
- Lengths Available:** 10.63", 18", 24", 30",
36", 48", and custom
order lengths
- Fitting Options:** 3/4" NPT, 1 1/4 NPT,
1" food grade,
1"/2"/3"/4" 150#
Raised Face Flanges
- Power Pac Options:** PROCAP I & II,
PROCAP IX & IIX,
PRO Remotes,
PRO Auto-Cal
- Applications:** Point level detection
and process control
for solid, liquid and
slurry materials.
Used in bins, tanks,
chutes, and spouts.

Designed with a 10" extended PRO-Shield, used when mounting the probe through a nozzle or standpipe. This probe has all the same features as the standard probe.

- Maximum Temp:** Delrin Sleeved
250° F. (121° C)
Teflon Sleeved
500° F. (260° C)
- Maximum Pressure:** 50 psi (3.5 kg/cm2)
1 1/4" NPT
500 psi (35 kg/cm2)
3/4" NPT
- Probe Material:** 5/8" dia. 316 SS
Delrin/Teflon
sleeved
- Lengths Available:** 15", 18", 24", 30",
36", 48", and custom
order lengths
- Fitting Options:** 3/4" NPT, 1 1/4"
NPT, 1" food grade,
1"/2"/3"/4" 150#
Raised Face Flanges
- Power Pac Options:** PROCAP I & II,
PROCAP IX & IIX,
PRO Remotes,
PRO Auto-Cal
- Applications:** Point level detection
and process control
for solid, liquid and
slurry materials.
Used when mounting
probe in a nozzle
or standpipe. Also
can be used when
excessive sidewall
buildup may occur.

Designed with a 6.5" overall length while still giving you the PRO-Shield protection. This probe is especially designed for low level applications where minimal projection is preferred due to restricted area or excessive weight that could damage a longer probe. This probe has all the same features as the standard probe.

- Maximum Temp:** Delrin Sleeved
250° F. (121° C)
Teflon Sleeved
500° F. (260° C)
- Maximum Pressure:** 50 psi (3.5 kg/cm2)
1 1/4" NPT
500 psi (35 kg/cm2)
3/4" NPT
- Probe Material:** 5/8" dia. 316 SS
Delrin/Teflon sleeved
- Lengths Available:** 6.5"
- Fitting Options:** 3/4" NPT, 1 1/4" NPT,
1" food grade,
1"/2"/3"/4" 150#
Raised Face Flanges
- Power Pac Options:** PROCAP I & II,
PROCAP IX & IIX,
PRO Remotes,
PRO Auto-Cal
- Applications:** Low level where
material/load on
probe may cause
damage or when
working in restricted
area or small vessel.

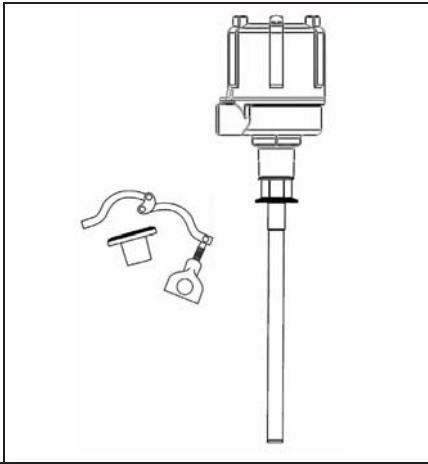

Shielded Delrin Sleeved Sanitary/3-A Probe

Sanitary Probe meets 3-A and USDA Standards, conforming to the food industry's most demanding requirements for material, surfaces, and clean-in-place construction. This probe is designed for quick disconnect from tank to facilitate ease of inspection and cleaning.

- Maximum Temp:** 250° F. (121° C)
- Maximum Pressure:** 200 psi (14 kg/cm2)
- Probe Material:** 5/8" dia. 316 SS Delrin sleeved
- Lengths Available:** 4", 6.5" 10.63", 18", 24", 30", 36", 48", and custom order lengths
- Fitting Options:** 1" or 2" Sanitary 316 SS Fitting for use with Tri-Clamp
- Power Pac Options:** PROCAP I 3-A & II 3-A
- Applications:** Point level detection and process control for solid, liquid and slurry materials. Built specifically for dairy, pharmaceutical, and food grade applications where 3-A/USDA sanitary standards apply. Used in bins, tanks, chutes, and spouts.

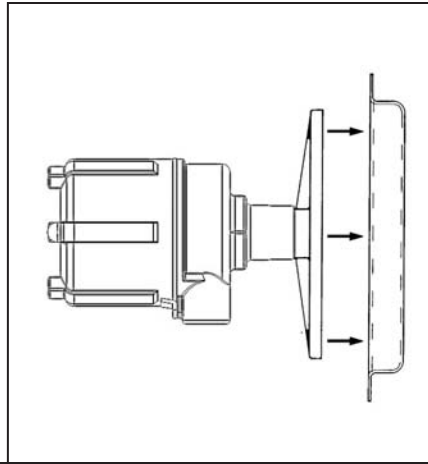

Flush Mounted Shielded Probe

No probe intrusion, designed for space constraint areas or applications where material flow or bridging may damage standard probes. The probe mounts flush on a vessel wall, conveyor housing or chute. A special bin wall adapter is available when working with thick walls or angled hoppers to move the face of the probe flush or slightly protruding with the inside of the vessel wall, eliminating false signals due to excessive buildup on the probe surface.

- Maximum Temp:** 150° F (65° C) standard Probe
450° F (232° C) High Temp. Probe
- Maximum Pressure:** 250 psi (17 kg/cm2)
- Probe Sensor Standard Probe Material:** Polyethylene High Temp. Probe Teflon
- Fitting Options:** 5.75" hole mounted on 7.00" bolt circle
8.50" hole mounted on 9.50" bolt circle when using bin wall adapter
- Power Pac Options:** PROCAP I & II, PROCAP IX & IIX, PRO Remotes, PRO Auto-Cal
- Applications:** Detects presence of material or level of materials that may bend or break probes when material shifts. Works well in coal, aggregate, gravel, or other heavy and/or chunky materials.

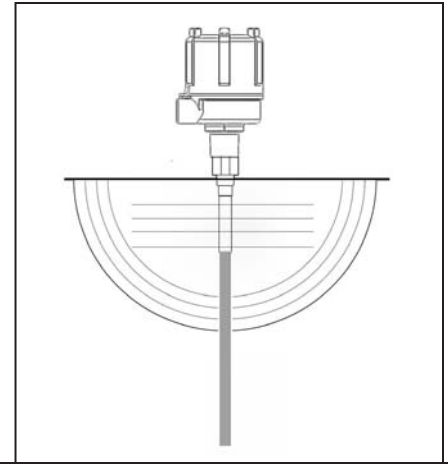

Bare Shielded OEM Probe

This is a bare shielded probe whose length can be modified in the field. It can be cut back to 7 inches or extended up to 8 feet. It has a rugged solid 5/8" dia. 316 SS probe featuring "PRO-Shield" protection against false readings because of coating or buildup.

- Maximum Temp:** 250° F. (121° C)
- Maximum Pressure:** 50 psi (3.5 kg/cm2) 1 1/4" NPT
500 psi (35 kg/cm2) 3/4" NPT
- Probe Material:** Standard Probe 5/8" dia. 316 SS/Bare with Delrin insulator
- Lengths Available:** 7 inches to 8 feet
- Fitting Options:** 3/4" NPT, 1 1/4" NPT, 1" food grade, 1 1/2"/3"/4" 150# Raised Face Flanges
- Power Pac Options:** PROCAP I & II, PRO Remotes, PRO Auto-Cal
- Applications:** Point level detection and process control for powders and dry bulk solid material that may have a tendency to build up and coat the probe. Used in bins, tanks, chutes, and spouts.

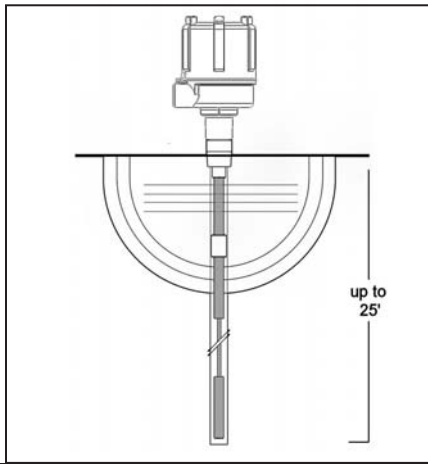

Shielded Teflon Sleeved 316 SS Hanging Flexible Cable Extension

The Teflon sleeved flexible cable extension was designed for high, mid, or low level when it is necessary to top mount. The flexible extension is also used in aggregate, coal or other lump materials that might damage a rigid probe or in materials that are not compatible with Stainless Steel. Maximum length of the cable and weighted probe end is 25 feet. The cable can be cut to length in the field.

- Maximum Temp:** 500° F (260° C)
- Maximum Pressure:** 50 psi (3.5 kg/cm2) 1 1/4" NPT
500 psi (35 kg/cm2) 3/4" NPT
- Probe Material:** 316 Stainless Steel 1/4" diameter cable with Teflon Sleeve and insulator
- Lengths Available:** 16 inches to 25 feet
- Fitting Options:** 3/4" NPT, 1 1/4 NPT, 1" food grade, 1 1/2"/3"/4" 150# Raised Face Flanges
- Power Pac Options:** PROCAP I & II, PROCAP IX & IIX, PRO Remotes, PRO Auto-Cal
- Applications:** Point level detection and process control for various solid, liquid and slurry applications when top-mounting. This Teflon sleeved probe should be used in applications where conductive material may leave residue on the probe (most liquids for instance). Note: Any conductive residue which builds up from the vessel wall to the active portion of any unsleeved bare probe will short out the two conductors.

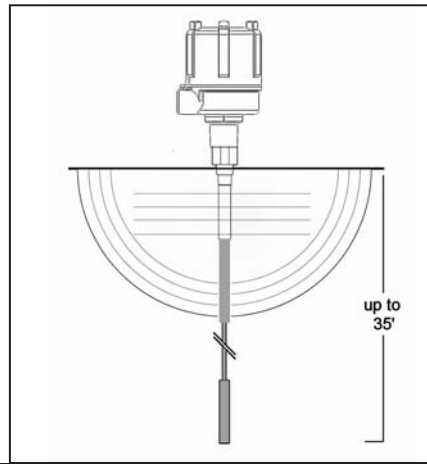

Shielded Bare 316 SS Hanging Flexible Extension

The flexible cable extension was designed for high, mid, or low level when it is necessary to top mount. The flexible extension is also used in aggregate, coal or other lump materials that might damage a rigid probe. This Flexible Cable Extension Probe features "PRO-Shield" protection against false readings because of coating or buildup. The Shielded probe also allows you to mount the probe in a standoff pipe or nozzle. Maximum length of the cable and weighted probe end is 35 feet. The cable can be cut to length in the field.

- Maximum Temp:** 250° F (121° C) Standard Probe
- Maximum Pressure:** 50 psi (3.5 kg/cm2) 1 1/4" NPT
500 psi (35 kg/cm2) 3/4" NPT
- Probe Material:** 316 Stainless Steel 1/4" diameter cable with Delrin insulator
- Lengths Available:** 16 inches to 35 feet
- Fitting Options:** 3/4" NPT, 1 1/4 NPT, 1" food grade, 1 1/2"/3"/4" 150# Raised Face Flange
- Power Pac Options:** PROCAP I & II, PRO Remotes, PRO Auto-Cal
- Applications:** Point level detection and process control for various solid, liquid and slurry applications when top-mounting.

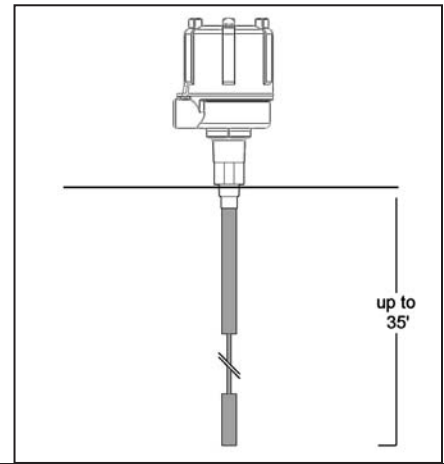

Unshielded Bare 316 SS Hanging Flexible Cable Extension

The flexible cable extension was designed for high, mid or low level detection when it is necessary to top mount. The flexible extension is also used in aggregate, coal or other lump materials that might damage a rigid probe. Maximum length of the cable and weighted probe end is 35 feet. The cable can be cut to length in the field.

- Maximum Temp:** 250° F (121° C) Standard Probe
500° F (260° C) High Temp Probe
- Maximum Pressure:** 50 psi (3.5 kg/cm2) 1 1/4" NPT
500 psi (35 kg/cm2) 3/4" NPT
- Probe Material:** Standard Probe 316 Stainless Steel 1/4" diameter cable with Delrin insulator
High Temp. Probe 316 Stainless Steel 1/4" diameter cable with Teflon insulator
- Lengths Available:** 16 inches to 35 feet
- Fitting Options:** 3/4" NPT, 1 1/4 NPT, 1" food grade, 1 1/2"/3"/4" 150# Raised Face Flange
- Power Pac Options:** PROCAP I & II, PRO Remotes, PRO Auto-Cal
- Applications:** Point level detection and process control for various solid, liquid and slurry applications when top-mounting.

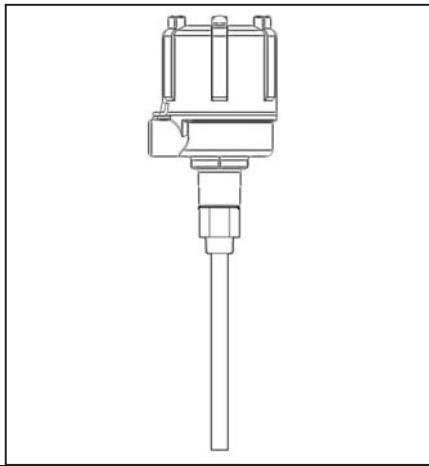

Unshielded Delrin/Teflon Sleeved Probe

The unshielded fully insulated Delrin/Teflon Sleeved probe was designed to be a lower cost, yet versatile probe. This all-purpose probe works reliably in bulk solids, powders, slurries, and liquids. It has a rugged solid 5/8" dia. 316 SS probe.

- Maximum Temp:** Delrin Sleeved
250° F. (121° C)
Teflon Sleeved
500° F. (260° C)
- Maximum Pressure:** 50 psi (3.5 kg/cm2)
1 1/4" NPT
500 psi (35 kg/cm2)
3/4" NPT
- Probe Material:** 5/8" dia. 316 SS Delrin
or Teflon sleeved
- Lengths Available:** 10.63", 18", 24", 30",
36", 48", and custom
- Fitting Options:** 3/4" NPT, 1 1/4" NPT,
1" food grade,
1"/2"/3"/4" 150#
Raised Face Flange
- Power Pac Options:** PROCAP I & II,
PROCAP IX & IIX,
PRO Remotes,
PRO Auto-Cal
- Applications:** Point level detection
and process control
for solid, liquid and
slurry materials. When
working with powders
and bulk solids, this
probe works best if top
mounted or side
mounted in vessels
with free-flowing
material where
excessive sidewall
buildup is not present.
Used in bins, tanks,
chutes, and spouts.

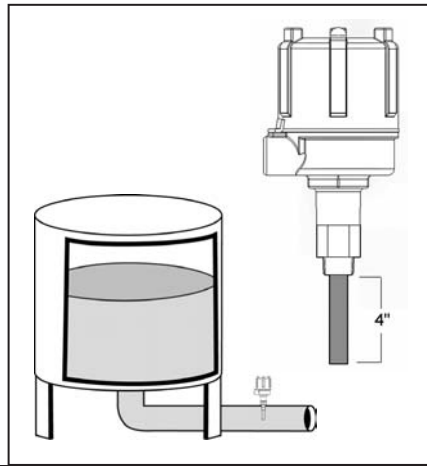

Stubby Unshielded Delrin/Teflon Sleeved Probe

The stubby unshielded probe is designed for minimal insertion into pipes, small hoppers, and in vessels where excessive buildup is not present. Also designed for low level applications where minimal insertion is preferred due to restricted areas or excessive weight that could damage a longer probe.

- Maximum Temp:** Delrin Sleeved
250° F. (121° C)
Teflon Sleeved
500° F. (260° C)
- Maximum Pressure:** 50 psi (3.5 kg/cm2)
1 1/4" NPT
500 psi (35 kg/cm2)
3/4" NPT
- Probe Material:** 5/8" dia. 316 SS Delrin
or Teflon sleeved
- Lengths Available:** 4"
- Fitting Options:** 3/4" NPT, 1 1/4" NPT,
1" food grade,
1"/2"/3"/4" 150#
Raised Face Flanges
- Power Pac Options:** PROCAP I & II,
PRO Remotes,
PRO Auto-Cal
- Applications:** Designed for minimal
insertion into pipes,
small hoppers,
vessels, or other
restricted areas.

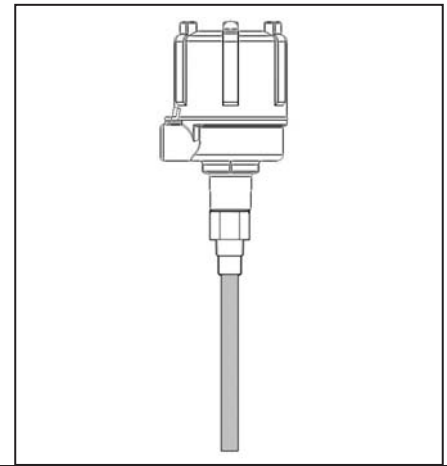

Unshielded Bare Stainless Steel Probe

An unshielded probe whose length can be modified in the field. It can be cut back to 3 inches or extended to 8 feet. The probe will work reliably in a variety of powders and dry bulk solid materials.

- Maximum Temp:** 250° F (121° C)
Standard Probe
500° F (260° C)
High Temp Probe
- Maximum Pressure:** 50 psi (3.5 kg/cm2)
1 1/4" NPT
500 psi (35 kg/cm2)
3/4" NPT
- Probe Material:** Standard Probe
5/8" dia. 316 SS/Bare
with Delrin insulator
High Temp. Probe
5/8" dia. 316 SS/Bare
with Teflon insulator
- Lengths Available:** 3", 4", 6", 10.19", 18",
24", 30", 36", 48", 72",
96", and custom
- Fitting Options:** 3/4" NPT, 1 1/4" NPT,
1" food grade,
1"/2"/3"/4" 150#
Raised Face Flange
- Power Pac Options:** PROCAP I & II,
PRO Remotes,
PRO Auto-Cal
- Applications:** Point level detection
and process control
for powder and dry
bulk solids. This probe
works best when top
mounted or side
mounted in vessels
with free-flowing dry
material where
excessive sidewall
buildup is not present.
Used in bins, tanks,
chutes, and spouts.

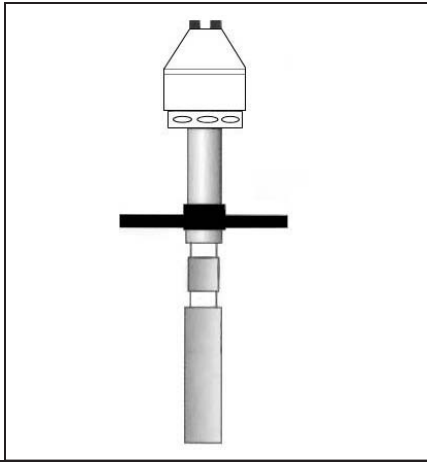

Shielded Bare Stainless Steel/Ceramic High Temperature Probe

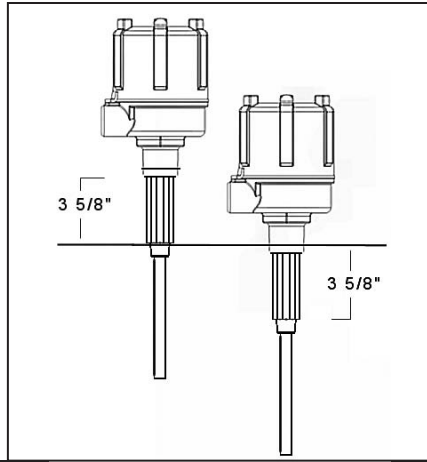

FI Fitting

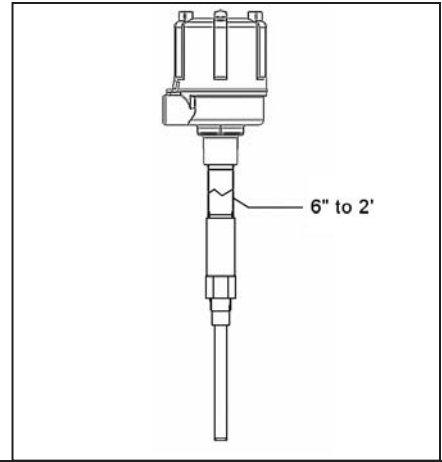

Stainless Steel or Galvanized Lag

The high temperature PRO Remote 20 capacitance probe is a heavy duty probe designed for applications that exceed 500° F (260° C). Stainless steel probe with ceramic inserts protects the probe from heat; remote electronics can be located up to 20 feet from probe.

- Maximum Temp:** 1000° F. (538°C)
- Maximum Pressure:** 100 psi (3.5 kg/cm2)
- Probe Material:** 1 1/8" dia. 316 SS
With Ceramic inserts
- Lengths Available:** 9" (230 mm)
- Fitting Options:** 1 1/4" NPT,
- Power Pac Options:** Remote Electronics only
- Applications:** Point level detection and process control for solid, liquid and slurry materials. Used in bins, tanks, chutes, and spouts.

The PROCAP FI Stainless Steel fitting is used to extend the probe 3 5/8" beyond the vessel wall to get past excessive buildup or through a thick wall. It can also be used to lag the electronics away from a heat source or clear external insulation. Extended Lag Fitting works with Bare and Delrin Sleeved Probe

- Maximum Temp:** Delrin Sleeved/Bare
250° F. (121°C)
- Maximum Pressure:** 50 psi (3.5 kg/cm2)
1 1/4" NPT
500 psi (35 kg/cm2)
3/4" NPT
- Fitting Material:** 316 SS
- Lengths Available:** 3 5/8"
- Fitting Options:** 3/4" NPT to lag out,
1 1/4" NPT to lag in
- Probe Options:** All Delrin Sleeved,
Bare, and Flexible probes
- Power Pac Options:** PROCAP I & II,
PRO Remotes,
PRO Auto-Cal
- Applications:** Point level detection and process control for solid, liquid and slurry materials. Used in bins, tanks, chutes, and spouts.

The Lagged Probe Fitting is used to extend the probe up to 2 ft. through thick vessel walls or double-walled hoppers and bins. It can be used to lag the electronics away from a heat source or to clear external insulation. Available in stainless steel or galvanized pipe.

- Maximum Temp:** Delrin Sleeved
250° F. (121°C)
Teflon Sleeved
500° F. (260 C)
- Maximum Pressure:** 50 psi (3.5 kg/cm2)
1 1/4" NPT
500 psi (35 kg/cm2)
3/4" NPT
- Lengths Available:** 6" to 24"
- Fitting Options:** 3/4" NPT to lag out,
1 1/4" NPT to lag in
- Probe Options:** All Delrin Sleeved,
Bare, and Flexible probes
- Power Pac Options:** PROCAP I & II,
PRO Remotes,
PRO Auto-Cal
- Applications:** Point level detection and process control for solid, liquid and slurry materials. Used in bins, tanks, chutes, and spouts.



Shipping Address: 7201 N. 98th St., Lincoln, NE 68507 / Mailing Address: P.O. Box 29709, Lincoln, NE 68529
Phone: 800-278-4241 or 402-434-9102 / Fax: 402-434-9133

www.binmaster.com / info@binmaster.com